



P.O. Box 247, 4320 Aerotech Center Way
 Paso Robles, CA 93447
 Telephone: (800) 350-2223 Fax: (805) 238-4201
 PAGE 1 OF 11 Page Rev. Date: 04/29/20
 P/N: SATURN

SATURN OVERDRIVE ASSEMBLY

KIT CONSISTS OF: 915670

No.	Qty	Part No.	Description
1.	1	915000	HOUSING ASSEMBLY
2.	1	911837	6 TOOTH SPIDER
3.	1	911223	26 TOOTH GEAR
4.	1	911806	LOCK WASHER
5.	1	911236	SNAP RING
6.	1	911131	BODY GASKET
7.	1	911133	OIL SCOOP
8.ASSY. 911223 TO SPIDER WITH THRUST BEARINGS			

KIT CONSISTS OF: 915672

No.	Qty	Part No.	Description
1.	1	915000	HOUSING ASSEMBLY
2.	1	911837	6 TOOTH SPIDER
3.	1	911224	29 TOOTH GEAR
4.	1	911806	LOCK WASHER
5.	1	911236	SNAP RING
6.	1	911131	BODY GASKET
7.	1	911133	OIL SCOOP
8.ASSY. 911224 TO SPIDER WITH THRUST BEARINGS			

KIT CONSISTS OF: 915674

No.	Qty	Part No.	Description
1.	1	915000	HOUSING ASSEMBLY
2.	1	911839	10 TOOTH SPIDER
3.	1	911224	29 TOOTH GEAR
4.	1	911806	LOCK WASHER
5.	1	911236	SNAP RING
6.	1	911131	BODY GASKET
7.	1	911133	OIL SCOOP
8.ASSY. 911224 TO SPIDER WITH THRUST BEARINGS			

KIT CONSISTS OF: 915676

No.	Qty	Part No.	Description
1.	1	915000	HOUSING ASSEMBLY
2.	1	911840	10 tooth spider metric
3.	1	911096	31 TOOTH GEAR
4.	1	911806	LOCK WASHER
5.	1	911236	SNAP RING
6.	1	911131	BODY GASKET
7.	1	911133	OIL SCOOP
8.ASSY. 911096 TO SPIDER WITH THRUST BEARINGS			
9.	4	724337	STAR WASHER
10.	5	911005	10MM X 90MM BOLT
11	1	911006	SEAL WASHER

KIT CONSISTS OF: 915677

No.	Qty	Part No.	Description
1.	1	915000	HOUSING ASSEMBLY
2.	1	911837	6 TOOTH SPIDER
3.	1	911806	LOCK WASHER
4.	1	911236	SNAP RING
5.	1	911131	BODY GASKET
6.	1	911133	OIL SCOOP
7.	1	911109	WASHER

8.	2	911100	THRUST WASHER
9.	2	911099	NEEDLE BEARING
10.	2	911094	THRUST WASHER
11.	2	914231	6-32 X 1/4 SHCS
12.	1	919869	SLINGER
13.	2	911091	GEAR BEARING

One of the most critical factors in performing a successful Saturn Overdrive installation, is the proper installation of the tabbed washer and special snap ring. If these are not properly installed, the overdrive assembly can slip out of position and cause gear damage that is not covered by warranty.

The second most important part of the installation is the proper alignment of the brass synchro ring onto the synchronizer assembly. Advance Adapters has installed the brass ring onto the synchro assembly by use of some heavy wheel bearing grease. This extra grease will maintain the proper location of the synchro ring while being installed onto the gear assembly. If there are any questions as you are performing this installation, please do not hesitate to call the factory for assistance.

The third most important part of the installation the oil supply, The oil scoop is the only way oil is fed to the bearings in the Saturn OD. We have seen units completely destroyed after just a 50 miles because the oil scoop was left off the unit.

SPECIAL NOTE: The components packaged in this kit have been assembled and machined for specific type of conversions. Modifications to any of the components will void any possible warranty or return privileges. If you do not fully understand modifications or changes that will be required to complete your conversion, we strongly recommend that you contact our sales department for more information. This instruction sheet is only to be used for the assembly of Advance Adapter components. We recommend that a service manual pertaining to your vehicle be obtained for specific torque values, wiring diagrams and other related equipment. These manuals are normally available at automotive dealerships and parts stores.

This all-range overdrive is a great addition to any of the early model Jeeps from 1940 to 1971, and I.H. Scouts 1961-65 with the Model 18 transfer case. The addition of this 25% overdrive unit offers you the needed gearing the early Jeeps were lacking. The Saturn overdrive is a fully synchronized unit that can be shifted-on-the-fly. When installing the unit, only minor modifications are required to the floorboard for the shifter. The Saturn is built to handle up to 300 ft./lbs. of torque, well within the range of a stock V8. **If you are interested in a lower gear set for your Dana 18 transfer case, but would like to retain your overdrive, we offer a Saturn bowl gear that will work with the gear reduction kits currently on the market. (See the Jeep Dana 18 & 20 Upgrade section for more information on low gear sets). If a low gear set is purchased, we have available a Saturn overdrive less the bowl gear.**

The Saturn is the original unit designed and developed by Warn Industries. Soon after their introduction, another unit emerged in Colorado by the name of Husky or Dual-A-Matic. The Colorado unit was identical in appearance, but in no way was it interchangeable with the Warn All-Range. Both units were available for the early Jeep and Scout vehicles. The units were offered with the 6 and 10 spline internal assembly and the 26 or 29 tooth output gear. Both units were very popular in the mid-1960s, but it wasn't until the introduction of the Dana Spicer Model 20 transfer case in 1972 that production quantities started to recede. The Warn and Husky overdrives were no longer compatible. Both companies stopped production, and the availability of spare parts became very scarce by the mid-1970s.

Advance Adapters purchased the tooling, engineering data, & inventory from Warn Industries in 1991. The components we manufacture today are the same as the old Warn components. We have incorporated a few upgrades on the units we sell today, but these units are all still interchangeable with the original Warn overdrive. (**Note:** The Saturn is not compatible with the Husky unit.) The Saturn overdrive installs directly on the backside of the transfer case through the inspection cover. No cutting or modification of the drivetrain is required. No relays and electrical connections required.

APPLICATION INFORMATION:

To select the proper overdrive model, find your vehicle model and transmission type listed below. The Saturn overdrive will only fit the vehicles listed that have a Dana 18 transfer case.

Part #	Description	Vehicle Models
915670	26T x 6 spline	M38, M38-A1, CJ2A, CJ3A, some CJ3B, 4-63 4X4, 4-73 4X4
915672	29T x 6 spline	CJ5, CJ5A, CJ6, CJ6A, 4-74 4X4, some CJ3B, 6-266, 6-230
915674	29T X 10 spline	(T14 trans) CJ5, CJ5A, CJ6, CJ6A
915676	31T X 10 spline	(Mitsubishi Jeep only)
915677	6 spline overdrive	(minus the bowl gear) designed for Tera Low low gear sets.
915678	27T x 6 spline	Some early Jeeps had a 27 thooth drive gear.

SHIFTER APPLICATION:

(Shifters are sold separately.)

Part #	Description
920000	T90 Dual Handle T/C
920001	T90 Single Handle T/C
920003	Universal Saturn Shifter
920013	T14 Shifter

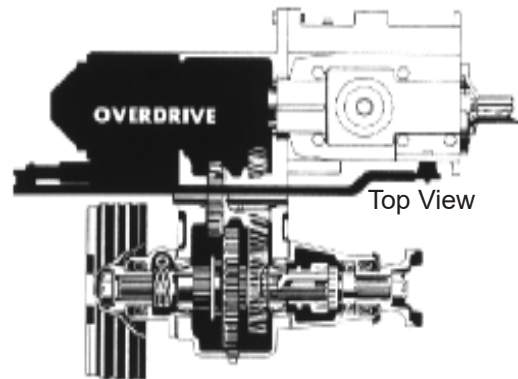

SATURN OVERDRIVE ONE (1) YEAR LIMITED WARRANTY

The manufacturer warrants this product against material defects and faulty workmanship for a period of one (1) year from the time of shipment on the Saturn Overdrive. We do not offer any type of labor allowance, and all warranty claims are subject to inspection by Advance Adapters. It is the customers responsibility to return possible warranted parts to Advance Adapters. The customer will be refunded for shipping costs incurred if the product is found faulty. We reserve the right to repair or replace any product. **All returns must have a Return Goods Authorization Number (RGA#).** Please call 1-800-350-2223, and our sales department can assist you. Warranty is void if proper gear lubricates are not used, the proper oil levels are not kept, the product has not been properly installed, and/or installation instructions have not been followed.

SATURN OVERDRIVE PARTS LIST

PART NO.	QTY REQ.	DESCRIPTION
911043	1	HEX NUT
911067	2	BRASS SYNCHRO-RING
911069	3	SYNCHRO DOG
911071	3	SYNCHRO SPRING
911078	1	SHIFTER SLIDER RING
911088	1	O'BRIAN'S 4WD BOWL GEAR
911090	4	PIN, PLANETARY GEAR
911091	2	NEEDLE BEARING
911092	1	26-TOOTH GEAR
911093	1	29-TOOTH GEAR
911094	2	THRUST RACE
911095	1	THRUST WASHER
911096	1	31-TOOTH GEAR
911097	1	27-TOOTH GEAR
911098	1	TERA LOW BOWL GEAR
911099	2	NEEDLE BEARING
911100	2	THRUST WASHER
911103	1	SHIFTER FORK
911105	1	SPRING, SHIFT DETENT
911106	1	SHIFT DETENT BALL
911107	1	SHIFT RAIL SEAL NEW STYLE
911108	1	SHIFT RAIL O-RING SEAL
911109	1	SPACER WASHER
911130	1	GASKET CASE
911131	1	GASKET BODY
911133	1	OIL SCOOP
911137	1	O-RING
911143	1	NEEDLE BEARING
716453	2	RETAINER RING SUN GEAR BEARING
911236	1	SPECIAL SNAP RING
911313	1	ROLLER BEARING
911316	4	THRUST WASHER
911326	1	BEARING CAP
911328	1	CASE COVER
911330	1	6 SPLINE SHAFT
911334	1	SPACER WASHER
911336	1	GASKET CAP
911337	1	STATIONARY MEMBER
911338	4	14-TOOTH GEAR
911341	8	THRUST WASHER
911342	8	NEEDLE BEARING STRIP
911346	1	DRIVE MEMBER
911731	1	DRIVE NUT
911731-S	1	SPECIAL METRIC DRIVE NUT
911806	1	LOCKWASHER
911838	1	RETAINER RING
912388	1	ROLL PIN
913296	1	SHIFTER SHAFT
913297	1	SHIFTER GUIDE PIN
914231	2	SOCKET HEAD SCREWS 6-32 X 1/4
914232	1	PLANET HUB ONLY-6 SPLINE
914384	1	PLANET HUB ONLY-10 SPLINE (T14)
914384-S	1	PLANET HUB ONLY SPECIAL 10 SPL.
914862	1	CAP SCREW SHIFTER
915132	1	COTTER PIN
915204	1	SATURN CASE
916779	1	SNAP RING/PLAN HUB
919866	1	RETAINING RING PLANET PINS
919869	1	RING OIL SLINGER

COMPONENT ASSEMBLY KITS

911349	SEAL AND GASKET KIT KIT INCLUDES ALL GASKET SEALS & SEAL WASHERS
912821	THRUST BEARING KIT KIT INCLUDES: (2) 911099 (2) 911094 (2) 911100
918963	4-PC PLANETARY GEAR SETS KIT INCLUDES: (8) 911341 (8) 911342 (4) 911316 (4) 911090 (4) 911338
911362	SPLINED SHAFT KIT KIT INCLUDES: (1) 911043 (1) 915132 (1) 911143 (2) 716453 (1) 911330
911317	SYNCHRO RING SERVICE KIT KIT INCLUDES: (2) 911067 (3) 911069 (3) 911071
911318	SYNCHRO ASSEMBLY KIT KIT INCLUDES: (2) 911067 (3) 911069 (3) 911071 (1) 911078 (1) 911346
911223	26 TOOTH PLANETARY HSG. KIT KIT INCLUDES: (1) 911092 (2) 911091 (1) 919869
911224	29 TOOTH PLANETARY HSG. KIT KIT INCLUDES: (1) 911093 (2) 911091 (1) 919869
911837	PLANETARY ASSEMBLY (6 SPL.) KIT INCLUDES: (1) 914232 (4) 911090 (1) 911095 (1) 911137 (4) 911316 (4) 911338 (8) 911341 (8) 911342 (1) 911731 (2) 919866 (1) 916779 (1) 911143

911839 -
PLANETARY ASSY. (T14 10 SPL.)
911840 -
PLANETARY ASSY. (METRIC 10 SPL.)
THESE KITS INCLUDE THE SAME PARTS AS 911837

SATURN INSTALLATION PROCEDURES

PAGE 5 OF 11 Page Rev. Date: 07-26-18

1. Drain and flush transfer case before starting with installation.
2. Put transmission into reverse gear and set hand brake. Remove shift knob, floor mat, and transmission floor plate.
3. Clean the transfer case and P.T.O. unit (if installed). Remove the rear cover plate or P.T.O. unit and clean all surfaces of gasket material and burrs. Using a socket wrench, remove the retaining nut that holds the stock drive gear in place. Remove the main drive gear (Fig 1) and make sure the new planetary gear assembly (Fig. 2) has the same number of exterior & interior teeth. Check the transmission main shaft for intermediate gear assembly. Replace any worn bearings and inspect the transmission rear output shaft bearing, replacing if necessary. (If installing Model No. 915674 overdrive unit be certain that the spacer between the transmission output bearing and the main drive gear is not removed. This spacer is only on the T14 3 speed transmission).
4. Install the planetary gear assembly onto the transmission main shaft. Using 1/2" socket drive, tighten the drive nut to 100-120 ft./lbs. torque. **DO NOT USE** an impact wrench. Install the special lockwasher (Fig. 3). This lockwasher prevents the drive nut from loosening. To retain the lockwasher, we have also provided a square snap ring that fits into the snap ring groove inside this planetary assembly. These items must be installed to prevent premature failure of this unit.

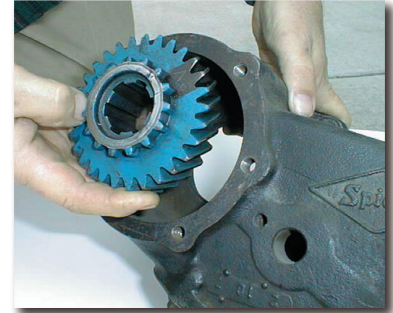

(Fig. 1)



(Fig. 2)

Square snap ring installation:

- a. Use "snap ring" or "needle nose" pliers to install.
- b. Compress the ring until the two ears touch. (If compressed beyond this point, the ring will collapse and will not be suitable for use).
- c. After installing, DOUBLE CHECK and make sure the retaining ring is properly seated in its groove.

NOTE: If the snap ring is not properly seated in its groove, the planetary unit will eventually work loose on the main shaft and cause severe damage to the overdrive unit.

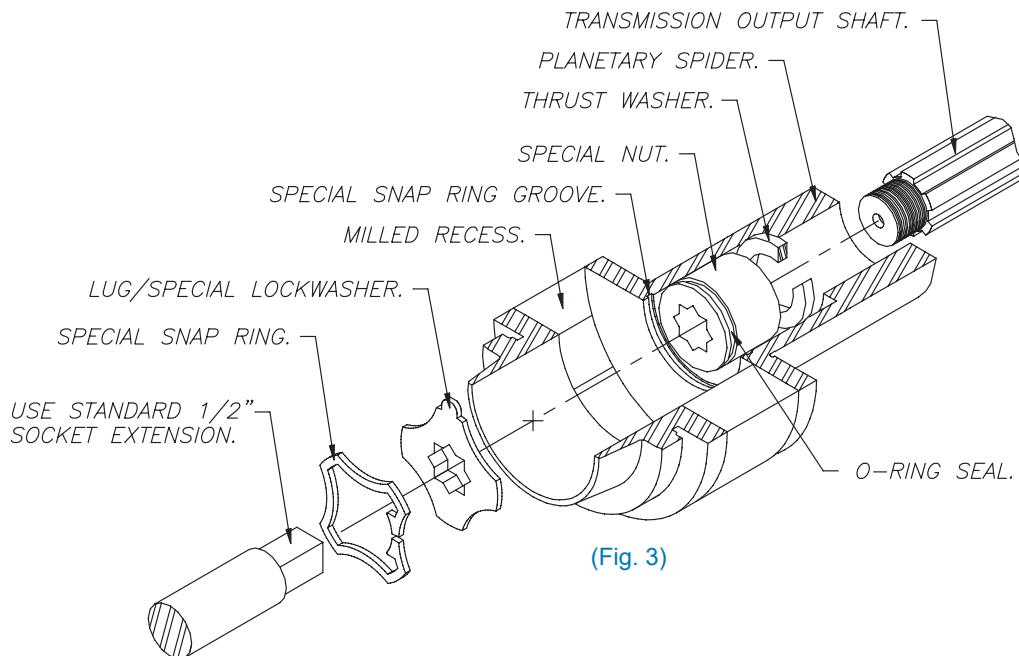

(Fig. 3)

5. Lift both rear wheels off the ground. Put transmission into neutral, transfer case in gear and release the hand brake. Turn driveline by hand to check for free rotation and run out. If rotation is not free, recheck Step 3 & 4.



(Fig. 4)

to make sure the brass synchro-ring is properly seated before mating these units together. The three steel keys must interlock with the brass synchro-ring. Use some bearing grease underneath the synchro-ring to prevent it from falling out of position during assembly. If the synchro-dogs do not line up properly, you will find a 1/4" gap between transfer case and overdrive housing. **DO NOT FORCE** these components together. We have seen failure occur because of synchro-ring misalignment.

Further precaution must be taken when installing your unit so that the planetary gears mesh properly. The overdrive unit may need to be rotated slightly to allow the gears to align correctly. Once the unit is mounted flush to your transfer case, install bolts with lock washers and tighten to 30 ft./lbs. torque. Make certain the seal washer is installed as shown in (Fig. 6). Turn the driveline by hand to check for free rotation.

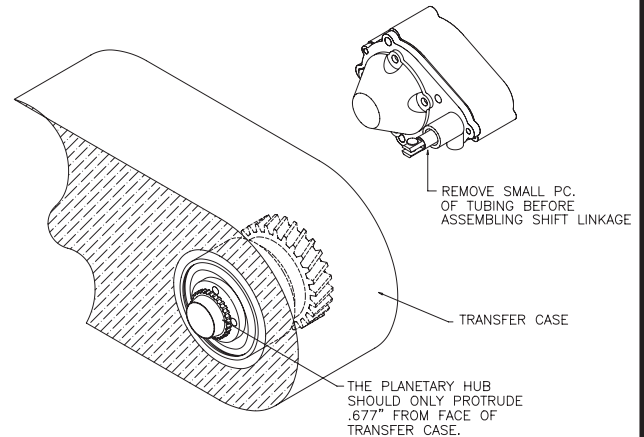

(Fig. 5)

9. Install the shifter pivot mount and handle assembly to the transmission case. Connect the shift lever rod to the overdrive unit and the shifter handle. Make sure you have proper clearance between shift rod, transfer case shifter, and vehicle body to assure quiet operation.
10. Using the new shift boot retainer plate as a pattern, mark and cut a new lever opening in your transmission floor plate (removed earlier). Install this modified floor plate. Install the shift boot retainer plate and shift boot.
11. Now is a good time to fill your transfer case with the proper lubrication. A high grade of gear oil (75-90w) is recommended. We **DO NOT** recommend the use of additives in the gear oil. The oil level in the transfer case must be maintained at proper levels to assure maximum overdrive durability.
12. Put the transfer case in neutral, the transmission in high gear, and the overdrive in the overdrive gear. Run the engine at a fast idle for 7 to 10 minutes. This will circulate the oil through overdrive unit. Stop the engine and recheck the oil level in transfer case, and refill if necessary.
13. About 100 miles after the installation of the overdrive, check and retighten the five (5) bolts that hold the overdrive unit to the transfer case (30 ft./lbs. torque) if necessary. Recheck the transfer case oil level once again.

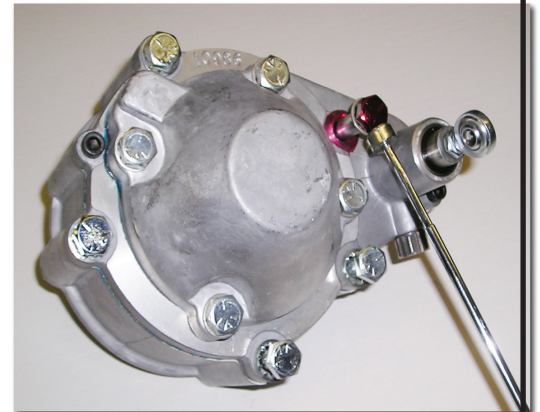

(Fig. 6)

OPERATION & USE:

Shifting the overdrive is done in the same manner as with a standard transmission, which is to release the throttle, depress the clutch pedal and shift. On automatic applications, the transmission should be shifted into neutral. When the shift lever in the forward position, the unit is engaged in overdrive. When the handle is shifted back towards the driver, the unit is in direct. The Saturn is designed mainly to be used as an overdrive; however, it can be used in any transmission gear-shifted in direct or overdrive. **Caution:** The unit should not be used in overdrive when towing or pulling a heavy load.

SATURN BREAKDOWN & ASSEMBLY INSTRUCTIONS

PAGE 7 OF 11
Page Rev. Date:
07-26-18

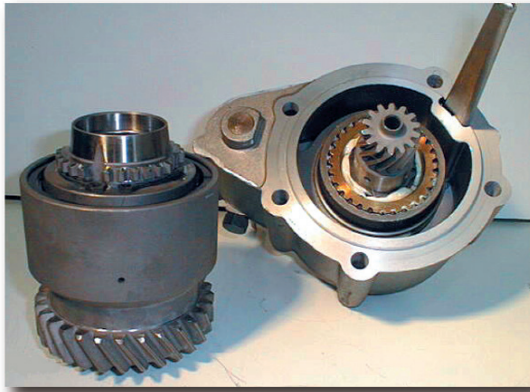

Planetary & Case Assembly

The overdrive has two basic parts which include the planetary gear assembly & case assembly.

DISASSEMBLY OF THE PLANATARY GEAR ASSY.



Step P1

Using a small flathead screwdriver, remove the snap ring from the gear housing.



Step P2

Using a 7/64" Allen wrench, remove the socket head screws holding the beveled spacer. (Early model Warn units used 2 roll pins).



Step P3

Remove the thrust bearing sets. Take note that the thickest race is next to the gear housing.



Step P4

Remove the thrust washers & bearing. Take note that the thin race is next to the spider assembly.

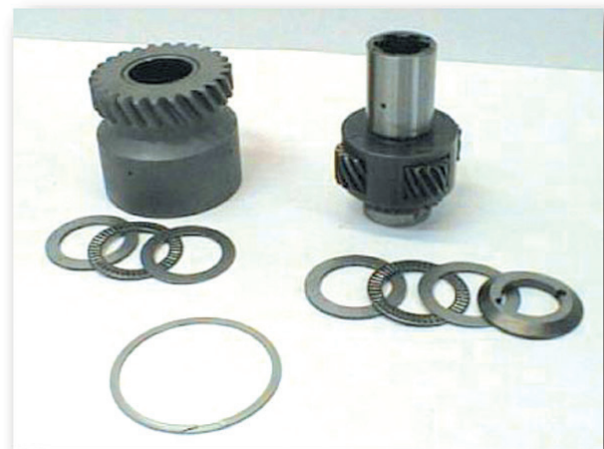

Step P5

Thoroughly clean & inspect all parts for wear. Replace if necessary.

Step 6

Planetary gears & bearings may be replaced by driving out the pins. (On some early model units, these pins were held in place by a small roll pin). By pushing the planetary pins out with a 5/16" drift punch, the roll pins will shear. Inspect the thrush washers, needle bearings, planetary pins and gears for wear.

Units produced today do not use the planetary pins retained by a roll pin. To keep these planetary pins in place we use a snap ring retainer that fits underneath the synchro-teeth.

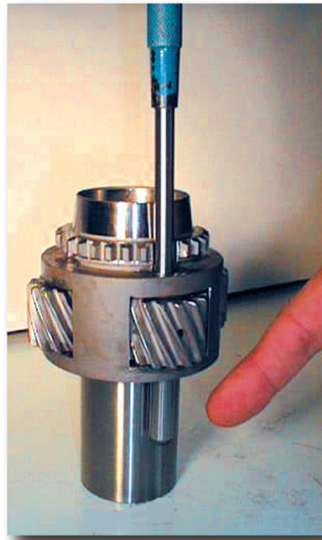

DISASSEMBLY OF THE CASE

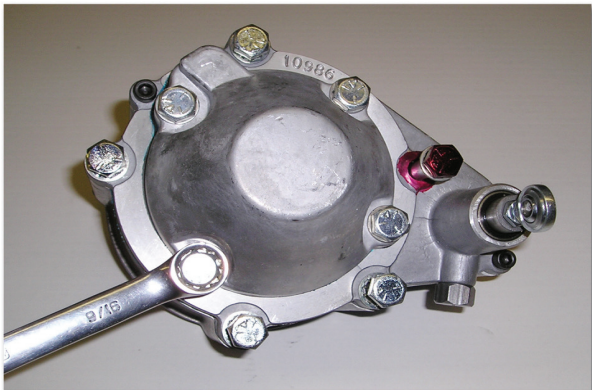

Step C1

Using a 9/16" wrench, remove the 4 cap screws holding the bearing cap.

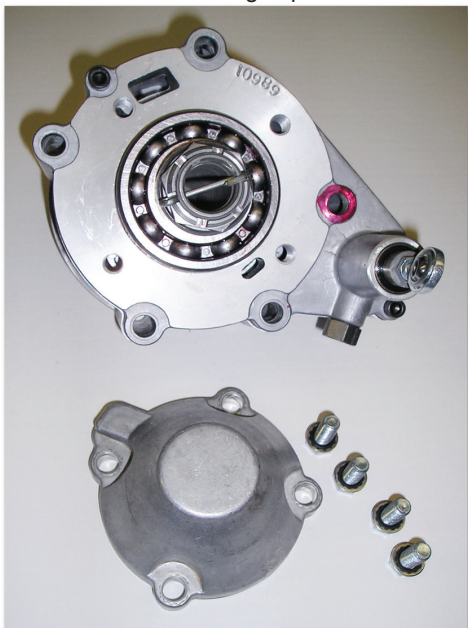

Bearing cap & screws removed. (During the reassembly, the 4-3/8" cap screws should be torqued to 19 ft./lbs., and the 1/4" cap screw to 6 ft./lbs. of torque)

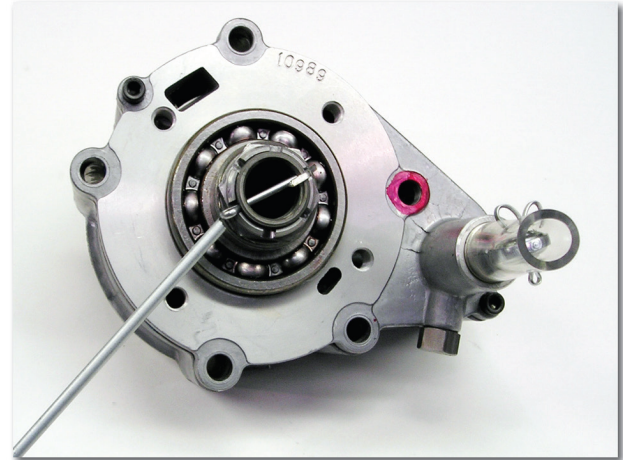

Step C2

Remove the cotter pin that locks the nut to the spline shaft.

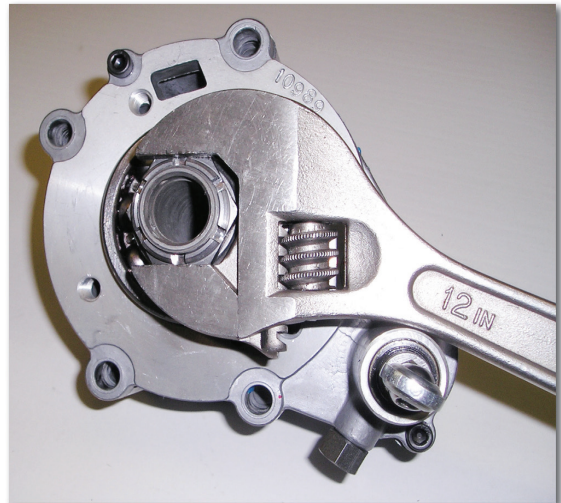

Step C3

Remove the nut using a 12" adjustable wrench. The shift fork must be at the rear of the case, locking the unit in the overdrive position before the nut can be removed. Castle nut is torqued at approx. 40 Ft.Lbs.

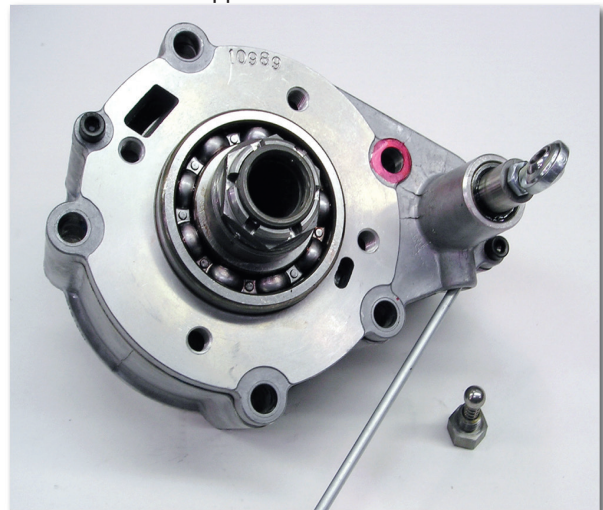

Step C4

Remove the shift detent screw, ball and spring.

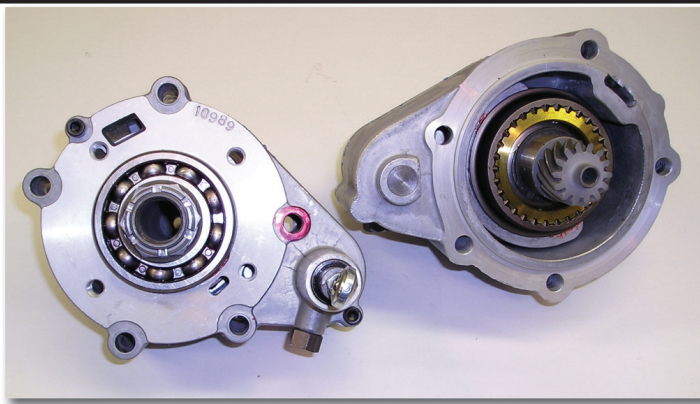

Step C5

Thoroughly clean and inspect all parts. Replace any if necessary. Reassemble the case assembly in the reverse order.

Step C6

Be certain that the notches in the rear synchro-rings are aligned with the shifter dogs when assembling. To properly retain the outer brass synchro-ring during assembly, we recommend using a quality grease to hold this ring in position. All internal components should be lubricated during reassembly using SAE 90w gear oil. Remember to install the oil scoop, as it is crucial for proper oiling of the unit.

SPECIAL CONSIDERATIONS:

The photo below represents the snap ring, lock ring, and retaining nut that fastens the planetary gear assembly to your transfer case. These items are only accessible once the case assembly has been removed. To remove the case assembly, unbolt the five (5) 3/8" bolts. The case assembly should then be removed. (NOTE: On high mileage units, the unit may be difficult to separate. This is due to the caged needle bearing that was originally pressed into the planetary hub. DO NOT disassemble the case assembly from the bearing cap inward.)

Once the case assembly has been removed, you should have access through the middle of the planetary housing to remove the snap ring, lock ring, and nut. See illustration below. Whenever the snap ring and lock ring are removed, they should be replaced with new components.

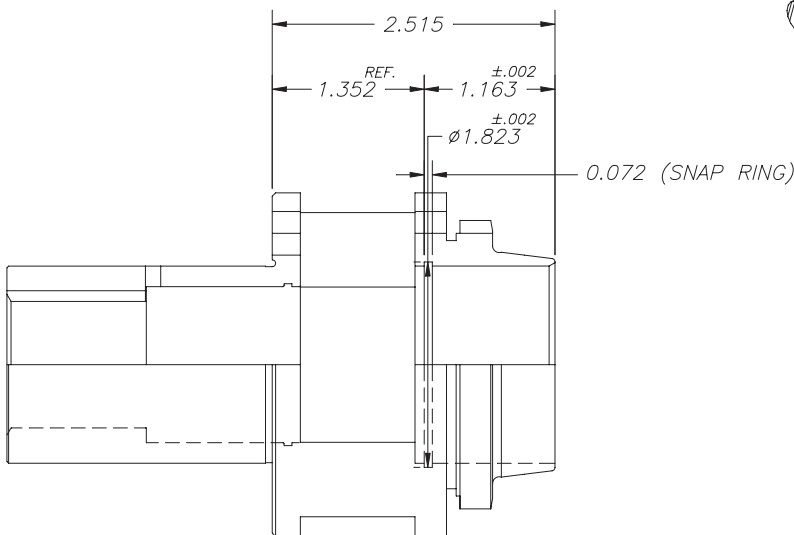
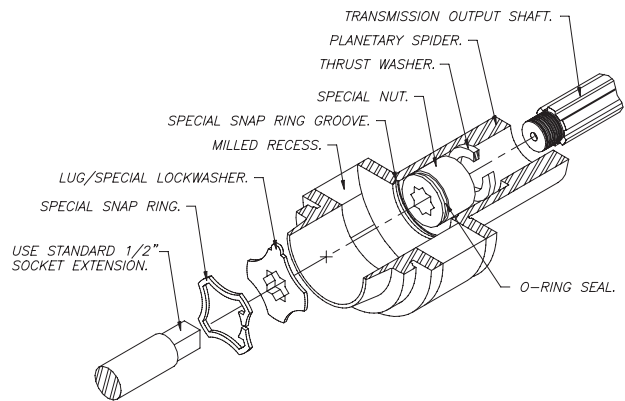
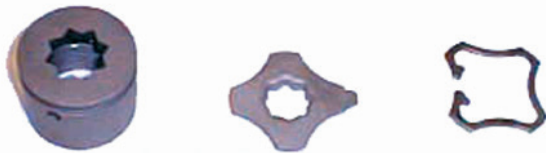

The design of the planetary housing has undergone a few changes from the early Warn & Saturn units.

One of the biggest problems when installing & removing this unit from a vehicle is the caged needle bearing that rides on the 6 spline shaft. This bearing required a pressed fit when installed into the planetary housing.

Today we have designed the planetary hub and the 6 spline shaft to simplify the installation & removal. Instead of the caged bearing being pre-installed on the 6 spline shaft, we now install it first in the planetary hub. This required a snap ring groove machined in the planetary hub. The retaining hub on the 6 spline shaft was removed. Current production of these 6 spline shafts, with the use of the older style planetary hub, will require this snap ring groove to be machined. Refer to the illustration on the left.

SATURN SHIFTER LINKAGE ASSEMBLY

There are 4 linkages available for the Saturn overdrive. Illustrated below is the linkage for a T90 dual lever transfer case. The pivot bracket on most linkages bolts to the 2 front top cover bolts of the transmission. The universal Saturn shifter bolts to the top 2 holes of the Dana 18 transfer case.

Little or no modifications will be necessary for linkages offered for the stock transmission assemblies. On the universal shifter application, some fabrication may be required. This is due to the various transmission assemblies that could be installed in the vehicle.

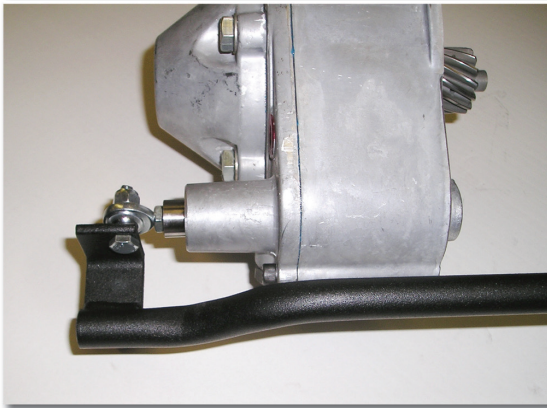
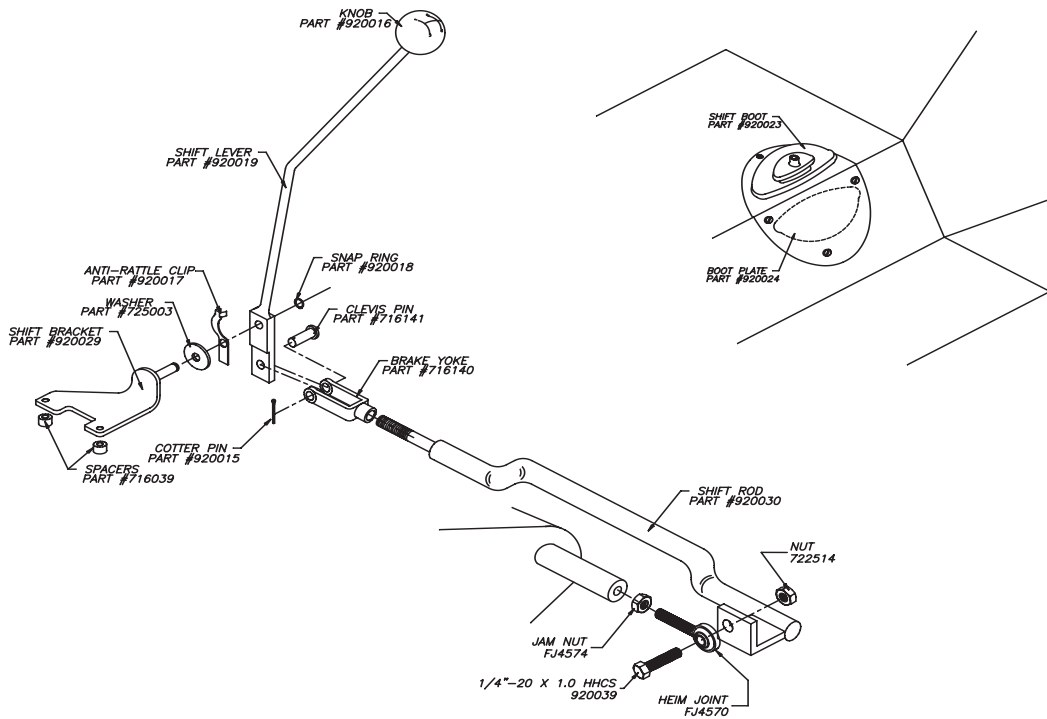

Both above photos illustrate the shift rod installation on the Saturn Overdrive. The shift rod must remain in close proximity to the overdrive unit for proper floorboard clearance. The configuration of some of the shifter rods are to avoid transfer case shifter lever interference.

SATURN SHIFTERS

P/N 920000	T90 Dual Lever T/C Shifter
P/N 920001	T90, T86 Single Lever T/C Shifter
P/N 920003	Universal Shifter
P/N 920013	T14 Shifter

SHIFTER COMPONENTS

P/N 920021	Dual Lever Rubber Boot
P/N 920022	Dual Lever Retainer Ring
P/N 920023	Universal Rubber Boot
P/N 920024	Universal Retainer Ring



Saturn installed with a Dana 18 twin stick shifter

