



P.O. Box 247, 4320 Aerotech Center Way  
Paso Robles, CA 93447  
Telephone: (800) 350-2223 Fax: (805) 238-4201  
PAGE 1 OF 3 Page Rev. Date: 06-19-17  
P/N: 50-6402A

## GM TH400 AUTOMATIC TO JEEP 1995 & NEWER NP231 T/C

### KIT CONSISTS OF:

No.	Qty	Part No.	Description
1.	1	51-6401	ADAPTER HOUSING (Ref: 711164-SS)
2.	1	52-3200	TH400 OUTPUT SHAFT (27-SPL) WELDED SHAFT
3.	1	716203	INPUT GEAR-NP231 27 SPLINE/ 716325A
4.	1	716165	SOFT PLUG
5.	1	716510	GASKET (GM #8624709)
6.	1	716517	GASKET
7.	1	716729	SEAL (NAT #456057)
8.	6	302071	3/8"-24 HEX NUTS
9.	6	723740	3/8"-16 x 1-1/2" S.H.C.S.

Note: output shaft was updated to 27 spline 6/17, Was a 23 spline before.

### GM TURBO 400 3 SPEED AUTOMATIC

The GM TH400 has a case length of 24-3/4", 13 bolts for holding the oil pan in position and is available in 3 different engine to transmission bolt patterns. Make sure you have selected the proper TH400 for your particular engine. The AMC TH400 case when used with the Chevy engine will require adapter Kit No. 716133. The rear side of the transmission case will have a hex shaped bolt pattern that uses 6 bolts. There are several various lengths of output shafts that these transmissions have been equipped with, but all of our new output shafts will be interchangeable with your transmission. The new shaft supplied with your kit should be installed by a competent mechanic. The speedometer gear is normally located in the tailhousing, but when adapting it to the transfer case, the location will change to the backside of the transfer case. The rear transmission support will now be located on the new adapter housing or, in some cases, on the transfer case.

When installing the new transfer case adapter, make sure that the input sleeve and the output shaft do not bottom out. We have found on occasion that a transmission output shaft may be slightly longer than we have allowed for. The adapter housing and shaft must be assembled to the back of the transmission without interference. **DO NOT FORCE THE NEW TAILHOUSING ONTO THE TRANSMISSION.** If assistance is needed, please feel free to call the number listed above.

When assembling the adapter housing to the transmission case, we have provided you with a new gasket to prevent fluid leakage. This gasket is a stock GM item that is used on all TH400 installations.

All installations will require the use of a transmission cooler. The cooler can be either installed in the radiator or a remote location is acceptable. The transmission shift control can either be a Hurst floor mounted type shifter or sometimes the existing column shift can be modified on certain applications.

**SPECIAL NOTE:** The components packaged in this kit have been assembled and machined for specific type of conversions. Modifications to any of the components will void any possible warranty or return privileges. If you do not fully understand modifications or changes that will be required to complete your conversion, we strongly recommend that you contact our sales department for more information. This instruction sheet is only to be used for the assembly of Advance Adapter components. We recommend that a service manual pertaining to your vehicle be obtained for specific torque values, wiring diagrams and other related equipment. These manuals are normally available at automotive dealerships and parts stores.

## GM TH400 AUTOMATIC TO JEEP 1987-94 NP231 T/C

### ASSEMBLY INSTRUCTIONS: All fasteners should be secured with green Loctite

1. Trial fit the adapter against the TH400. If it will not fit flush against the transmission, then grind a small portion around the speedometer gear housing.
2. The provided steel plug is used to close the original speedometer drive hole. Use a socket roughly the same I.D. as the cup side of the plug and drive it into the case. All original speedometer parts must be removed prior to this step.
3. Install the new output shaft provided by Advance Adapters. This should be done by an experienced transmission technician.
4. Apply silicone sealant to the TH400 to adapter gasket. Assemble the adapter to the transmission with the six 3/8"-16 x 1-1/2" socket head cap screws.
5. Check the stickout length of the output shaft with reference to the adapter housing. It should not stick out more than 7/16" (.4375 in.).
6. Trial fit the transfer case to the adapter casting. **DO NOT "SUCK-UP" THE TRANSFER CASE WITH THE STUDS! SEVERE DAMAGE WILL OCCUR.**
7. Install the seal into the casting with open side of the seal facing the transmission.
8. Apply a thin coat of silicone sealant to the transfer case gasket. Install the transfer case and secure it with Loctite, nuts and lockwashers.

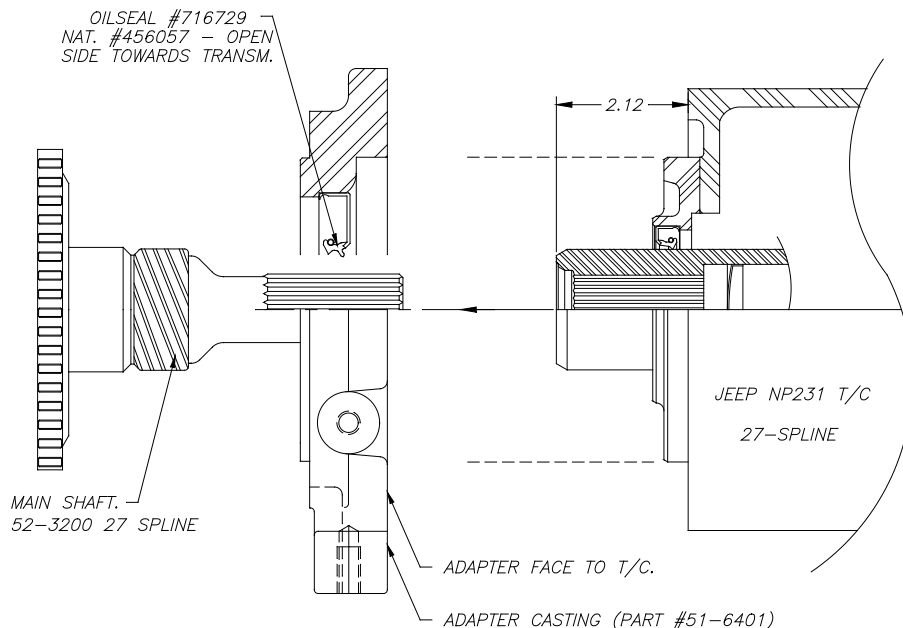

### INSTRUCTIONS for NP 231 input gear:

This new input gear will only fit the NP231 transfer cases. The installation of the gear will require the complete disassembly of your NP231 transfer case. Since the transfer case has to be completely disassembled, this is also a good time to install a short output shaft kit (fixed yoke kit) if you already have not done so.

If you've never disassembled a New Process transfer case, here are a couple of points to keep in mind that will make the installation much easier:

1. Keep all bolts, nuts, washers, etc. separated into groups as you remove them. Make sure you keep them in a labeled container that indicates what part of the transfer case they came from.
2. Keep all small parts in separate containers and label as to location and origin.
3. Make sure you have plenty of time and have a clean, spacious area to perform the installation.

**SPECIAL NOTE:** The components packaged in this kit have been assembled and machined for specific type of conversions. Modifications to any of the components will void any possible warranty or return privileges. If you do not fully understand modifications or changes that will be required to complete your conversion, we strongly recommend that you contact our sales department for more information. This instruction sheet is only to be used for the assembly of Advance Adapter components. We recommend that a service manual pertaining to your vehicle be obtained for specific torque values, wiring diagrams and other related equipment. These manuals are normally available at automotive dealerships and parts stores.

## GM TH400 AUTOMATIC TO JEEP 1987-94 NP231 T/C

Remove the front yoke nut with a 1-1/8" socket using an impact wrench. Remove the rear case bolts. A 10mm 12 pt. socket is needed for the spline head bolt and a 15mm socket for the remaining bolts.  
**NOTE:** The two black oxide finished bolts are located at the case dowel positions and require a washer under them. Start to remove the rear case from the front case by inserting pry bars at the cast-in locations **ONLY!** Pry apart evenly to break the sealer bead along the case mating surfaces. The front output shaft and chain should be retained with the rear portion of the case.



On the front side of the transfer case, you'll need to remove the 4 bolts that retain the aluminum bearing retainer. Once this is removed, you'll find a snap ring that retains the input gear to the cases' input bearing. This snap ring must be removed so that the input gear can be removed from the inside.



On the inside of the transfer case, you'll now be able to remove the planetary assembly. Set the assembly on a work bench and locate the snap ring that retains the input gear into the planetary housing. Remove the snap ring and lift the input gear out of the planetary housing.

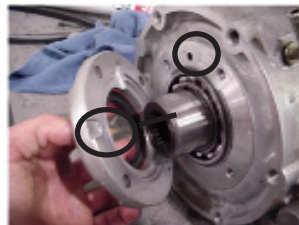

Once you have verified that you have the same style input gear, install the gear into the planetary, install the snap ring. Re-install the planetary assembly into the case and secure the input to the bearing with the front snap ring. **Note:** The only part you should have left out of the case is the old input gear. During reassembly, make sure the oil return hole matches the front retainer hole.

Once the input gear is removed, you'll find a thrust washer that must be reinstalled onto the new 27 spline input. When comparing the two input gears, they should look the same except for the internal splines. If you find a difference between the two. The NP231 transfer case used two styles of front input bearings. The early transfer case used a wide bearing and the later model used a narrow bearing. This new input gear is designed for only the early style case. New Process changed the bearing and gear pitch design in 1995. The center photo below show a later model input compared to a early.

**SPECIAL NOTE:** The components packaged in this kit have been assembled and machined for specific type of conversions. Modifications to any of the components will void any possible warranty or return privileges. If you do not fully understand modifications or changes that will be required to complete your conversion, we strongly recommend that you contact our sales department for more information. This instruction sheet is only to be used for the assembly of Advance Adapter components. We recommend that a service manual pertaining to your vehicle be obtained for specific torque values, wiring diagrams and other related equipment. These manuals are normally available at automotive dealerships and parts stores.