

# ADVANCE ADAPTERS INC.

P.O. Box 247, 4320 Aerotech Center Way

Paso Robles, CA 93447

Telephone: (800) 350-2223 Fax: (805) 238-4201

# P/N: 27-3525C

New Item: (08/07)

PAGE 1 OF 5

Page Rev. Date: 10-28-24

## AX15 TO 1966-77 FORD BRONCO COYOTE ENGINE

### KIT CONSISTS OF:

No.	Qty	Part No.	Description
1.	1	26-AX15	TRANSMISSION- AX15 4WD NEW UNIT .750 TIP (BOXED)
2.	1KIT	50-9920A	JEEP AX15 TRANSXBRONCO DANA 20
3.	1	711543	ADAPTER- SBF BH TO JP AX15
4.	1KIT	716000A	AX15 TO BRONCO CROSSMEMBER
5.	1KIT	716099A	SQUARE STYLE NV3550 SHFT HANDLE
6.	1	716742	SEAL-TOYOTA AX15 RETAINER
7.	9	720030	10mm X 1.25 X 30mm S.H.C.S.
8.	8	720040	S.H.C.S. 8mm X 1.25 X 20mm black oxide
9.	4	723137	5/16 -18 X 1 S.H.C.S.
10.	4	724317	S.H.C.S. 7/16 -14 X 1-1/4
11.	1	761019	RETAINER- FORD FRONT BEARING 4.849
12.	1	712546	COYOTE BELLHOUSING KIT
13.	1	712546G	CLUTCH DISC FOR THE 712546 KIT

### ADVANCE ADAPTERS ASSEMBLY NOTE:

1. Bellhousing adapter kits to be installed and transmission to be modified before boxing unit.

### SPECIAL NOTE:

1. No driveline modifications necessary.
2. The AX15 assembly is 1/4" shorter than the factory 3 speed or 4 speed.
3. The AX15 is slightly taller than the stock 3 or 4 speed. A 1" body lift is recommended for the best transmission alignment.



**SPECIAL NOTE:** The components packaged in this kit have been assembled and machined for specific type of conversions. Modifications to any of the components will void any possible warranty or return privileges. If you do not fully understand modifications or changes that will be required to complete your conversion, we strongly recommend that you contact our sales department for more information. This instruction sheet is only to be used for the assembly of Advance Adapter components. We recommend that a service manual pertaining to your vehicle be obtained for specific torque values, wiring diagrams and other related equipment. These manuals are normally available at automotive dealerships and parts stores.

# ADVANCE ADAPTERS INC.

P.O. Box 247, 4320 Aerotech Center Way  
Paso Robles, CA 93447  
Telephone: (800) 350-2223 Fax: (805) 238-4201

P/N: 27-3525C

New Item: (08/07)  
PAGE 2 OF 5  
Page Rev. Date: 12/28/24

## AX15 TO 1966-77 FORD BRONCO COYOTE ENGINE

### INSTALLATION PROCEDURES:



#### **STEP 1:**

##### **Preparing the AX15 transmission for the bellhousing adapter**

Match the bellhousing adapter to the front of the AX15. Mark the transmission where the top two holes of the adapter meet the front flange. A small notch will need to be ground into the flange to provide clearance for the bolts. Carefully use an angle or die grinder to grind the clearance for the bolts. **NOTE:** The AX15 has an aluminum case. This material grinds very easily.



#### **STEP 2:**

##### **Bellhousing adapter plate installation**

Install the bellhousing adapter plate to the AX15 using (9) Allen bolts supplied. **NOTE:** Use Loctite.

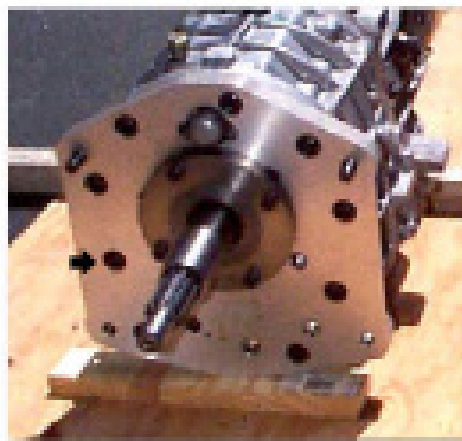

#### **STEP 3:**

##### **Removing the original transmission**

Remove the driveshafts, shifter cables, and exhaust (if necessary). Remove the original transmission and transfer case assembly from the vehicle. Leave the bellhousing in the vehicle.

**SPECIAL NOTE:** The components packaged in this kit have been assembled and machined for specific type of conversions. Modifications to any of the components will void any possible warranty or return privileges. If you do not fully understand modifications or changes that will be required to complete your conversion, we strongly recommend that you contact our sales department for more information. This instruction sheet is only to be used for the assembly of Advance Adapter components. We recommend that a service manual pertaining to your vehicle be obtained for specific torque values, wiring diagrams and other related equipment. These manuals are normally available at automotive dealerships and parts stores.

# ADVANCE ADAPTERS INC.

P.O. Box 247, 4320 Aerotech Center Way  
Paso Robles, CA 93447  
Telephone: (800) 350-2223 Fax: (805) 238-4201

P/N: 27-3525C

New Item: (08/07)  
PAGE 3 OF 5  
Page Rev. Date: 11/28/24

## AX15 TO 1966-77 FORD BRONCO COYOTE ENGINE

### STEP 4:

#### Transfer case adapter to Dana 20

Remove the transfer case adapter and stub shaft from the original transmission. Apply the new AA gasket to the transfer case. Aligning the transfer case adapter with the most clockwise holes will match to the factory indexing (lowest setting). You can use the other set of holes for a higher rotation; however, this can cause some problems with body clearance, frame clearance, and transfer case shifter linkage alignment. The higher rotation does give you better ground clearance and is a nicer fit on to the new crossmember mount provided.

Note: A shifter bracket has been provided for a "T" style T/C shifter handle. Before installing your transmission and transfer case assembly in your vehicle, check the fit of this linkage and bracket. The transfer case shifter handle and the AX15 shifter handle may be too close together on some applications. The AX15 or the "T" handle may require a small bend to clear each other.

Once you have chosen the rotation, use Loctite and install the (6) Allen bolts.

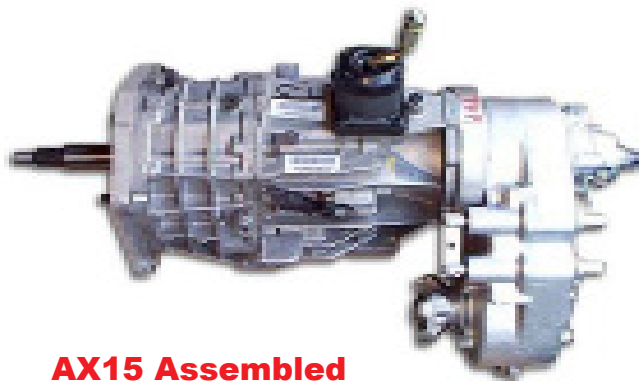

**AX15 Assembled**

### STEP 5:

#### Installing the adapter and transfer case assembly to the AX15

Grease the AX15 tail shaft splines and install the stub shaft & bearing assembly. Apply light grease to the o-ring and attach the transfer case to the transmission with (6) bolts using Loctite. Use the driver's side top 2 bolts to attach the transfer case shifter bracket.

### STEP 6:

#### Prepare the body for the shifter hole

Measure the AX15 (with the front adapter plate installed) from the edge to the shift tower. It is best to make a template. Measure the location on the body to be cut for the new shifter. **NOTE:** To find your measurement, it is best to do this with the bellhousing still installed.

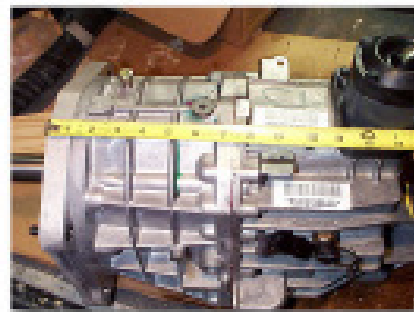

**SPECIAL NOTE:** The components packaged in this kit have been assembled and machined for specific type of conversions. Modifications to any of the components will void any possible warranty or return privileges. If you do not fully understand modifications or changes that will be required to complete your conversion, we strongly recommend that you contact our sales department for more information. This instruction sheet is only to be used for the assembly of Advance Adapter components. We recommend that a service manual pertaining to your vehicle be obtained for specific torque values, wiring diagrams and other related equipment. These manuals are normally available at automotive dealerships and parts stores.

# ADVANCE ADAPTERS INC.

P.O. Box 247, 4320 Aerotech Center Way  
Paso Robles, CA 93447  
Telephone: (800) 350-2223 Fax: (805) 238-4201

P/N: 27-3525C

New Item: (08/07)  
PAGE 4 OF 5  
Page Rev. Date: 10/28/24

## AX15 TO 1966-77 FORD BRONCO COYOTE ENGINE

### STEP 6:

#### Installing the new clutch & bellhousing assembly

Use Loctite on the flywheel bolts if they were removed. Remove the original pilot bushing from the flywheel and install the new AA pilot bushing (**do not grease pilot bushing**).

Install the new disc and pressure plate to the flywheel. Install the new throw out bearing and arm to the bellhousing and grease with an anti-seize lube.

Install the bellhousing and torque to factory specifications.

### Step 7:

#### Installing the shifter into the body hole

Remove the shift tower from the AX15 (4 bolts). Slide it through the hole in the body and use a string to hold it in place. This makes the transmission installation easier, as the shifter tower does not interfere with the body. When removing the shifter tower, make sure the shifter hole on the transmission is covered to keep debris out of the transmission.

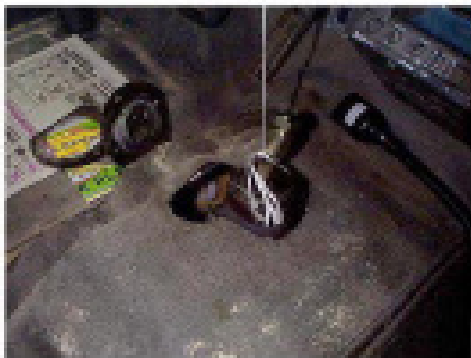

### STEP 8:

#### Installing the transmission assembly into the Bronco

We recommend using a transmission jack. Once the transmission has been installed and bolted to the bellhousing, you will be required to reinstall the transmission shift tower.



### STEP 9:

#### Installation of the transmission crossmember

For installation, see Instruction Sheet 716000.



**SPECIAL NOTE:** The components packaged in this kit have been assembled and machined for specific type of conversions. Modifications to any of the components will void any possible warranty or return privileges. If you do not fully understand modifications or changes that will be required to complete your conversion, we strongly recommend that you contact our sales department for more information. This instruction sheet is only to be used for the assembly of Advance Adapter components. We recommend that a service manual pertaining to your vehicle be obtained for specific torque values, wiring diagrams and other related equipment. These manuals are normally available at automotive dealerships and parts stores.

# ADVANCE ADAPTERS INC.

P.O. Box 247, 4320 Aerotech Center Way  
Paso Robles, CA 93447  
Telephone: (800) 350-2223 Fax: (805) 238-4201

## P/N: 27-3525C

New Item: (08/07)  
PAGE 5 OF 5  
Page Rev. Date: 10/28/24

## AX15 TO 1966-77 FORD BRONCO COYOTE ENGINE

### AX15:

The AX15 transmission is an ideal transmission swap for the early Broncos. This 5 speed is rated at 300 ft./lbs. at 7200 GVW. A stock Bronco weighs 4200 GVW. When installed into a Bronco, the AX15 can then handle an even a higher torque rating due to the lower vehicle weight - so strength is not an issue. The weight of this 5 speed is 97 lbs., which is similar to the stock 3 speed & 4 speed transmissions. The overall size and length make it an ideal fit. This transmission will adapt to either the stock Dana 20 or to our Atlas transfer case.

### The gearing of this 5 speed is as follows:



1st	4.01
2nd	2.32
3rd	1.40
4th	1.00
5th	0.78
Rev	3.57

### Low gear ratio options: and Dana 20 (2.46:1)

1st	4.01
2nd	2.32
3rd	1.40
4th	1.00
5th	0.78

### Vehicle with 4.56 axle and Atlas (4.30:1)

44.99:1
26.03:1
15.70:1
11.22:1
8.76:1

### Vehicle with 4.56 axle

78.62:1
45.49:1
27.45:1
19.60:1
14.87:1

### Freeway speed information: (Vehicle with 33" tires and 4.56 gears in 5th gear would have the following RPM's)

MPH	RPM
55	1993
65	2355
70	2537
75	2718

### Gear Oil:

The AX15 uses a special gear oil only available from your Chrysler

