

BRONCO C4 ATLAS II SHIFTER

KIT CONSISTS OF:

No.	Qty	Part No.	Description
1.	1 Kit	302010	ATLAS BAGGED HARDWARE KIT
2.	1 Kit	302011	ATLAS BOOT & KNOB KIT
3.	1	302051	TWIN STICK BASE MOUNT
4.	1	302065	TWIN STICK TUBE 2.125"
5.	6"	303100	3/8" HEAT SHRINK
6.	3	303121	HEX JAM NUT 1/2"-13 PLATED
7.	1	303130	TWIN STICK LEVER (BRONCO)
8.	1	303131	TWIN STICK LEVER (BRONCO)
9.	2	723756	3/8"-24 x 3.25" ALL THREAD GRD 5
10.	1	725045	1/2"-13 x 5" STUD BOLT



NOTE: For the complete shifter installation procedures, please refer to the tech vault section on the web.

As of January 1, 2005, we have changed the design of our shifter tower. We no longer use a set of Zerk fittings on the tower and have omitted the white nylon bushings. The new design uses a Igus black bushing which does not require grease. These bushings are not interchangeable.

White bushings: 303080 (large) 4 required
303095 (small) 4 required
Black bushings: 303081 (large) 4 required
303096 (small) 4 required

The shift tower in this photo as shown would index onto the D.O.M. tubing and would fit a left drop case. Right drop cases would require the tower to be flip to the other side to index over the D.O.M. tubing.

A 1" body lift is recommended to aid in clearance for the new Atlas twin stick shifter.

SPECIAL NOTE: THE SHIFT HANDLES AND SHIFT BUTTONS SHOWN IN THE ATLAS MANUAL DO NOT REPRESENT THE PROPER ORIENTATION FOR THE BRONCO SHIFTER. THE BUTTONS & SHIFT HANDLES SHOULD LOOK LIKE THE PHOTO'S FOUND ON PAGE 2 & 3. THE ILLUSTRATIONS ARE TO SHOW THE BASIC CONFIGURATION OF THE ATLAS SHIFTER.

SPECIAL NOTE: The components packaged in this kit have been assembled and machined for specific type of conversions. Modifications to any of the components will void any possible warranty or return privileges. If you do not fully understand modifications or changes that will be required to complete your conversion, we strongly recommend that you contact our sales department for more information. This instruction sheet is only to be used for the assembly of Advance Adapter components. We recommend that a service manual pertaining to your vehicle be obtained for specific torque values, wiring diagrams and other related equipment. These manuals are normally available at automotive dealerships and parts stores.

BRONCO ATLAS II SHIFTER



On the Bronco that we installed the Atlas transfer case into, the shifter tower rotation should look something like this.

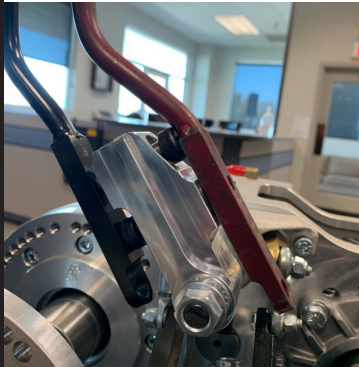
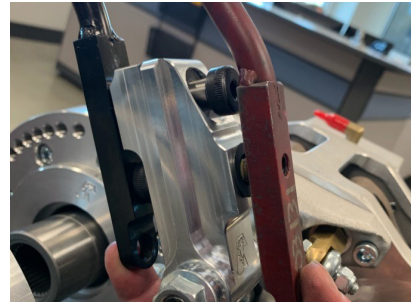

The Bronco handles installed on the Atlas

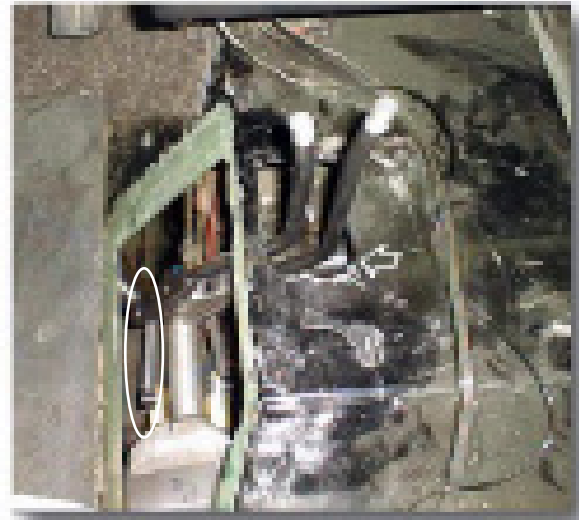

Inside the vehicle, we removed the side inspection cover for easier linkage installation. (Notice the brass shift rod rotation and the shift button configuration). Also, a small amount of material from the floor board was removed.

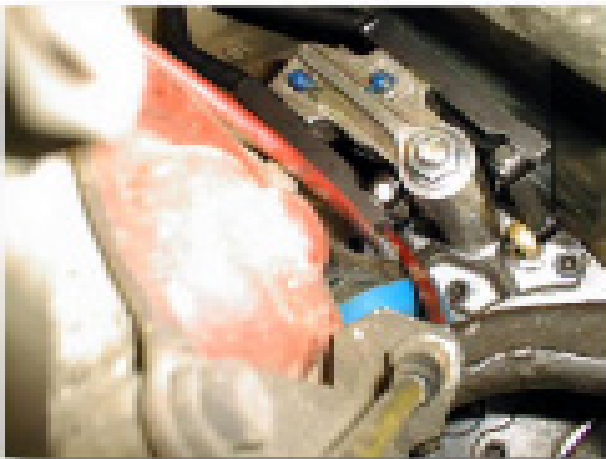

Looking back from the drivers side of the C4 transmission, this is how the shifter linkage should look installed in the vehicle.

BRONCO ATLAS II SHIFTER

This kit was designed to fit the stock shifter hole. On some applications, customers have modified their inspection cover and brought the shift handles through a new hole. (This may be necessary on some manual transmission applications).

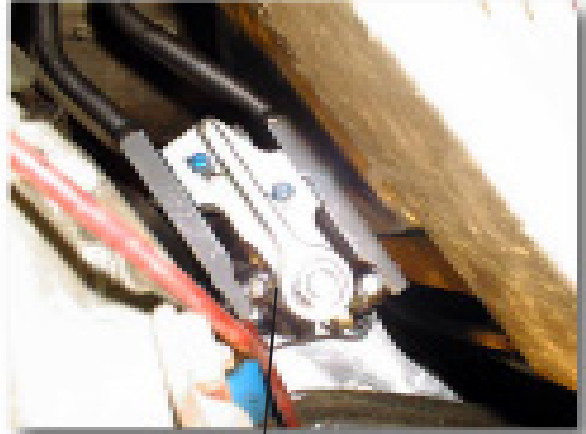

Some grinding will be necessary on the shifter tower to allow clearance for the shifter button.



The new twin stick boot covers the stock transfer case hole.

The Atlas with C4 transmission final installation.



SHIFTER INSTALLATION (2sp and 4sp main case)

1. Install the shifter base to the face of the Atlas using the three S.H.C.S. 3/8"-16 x 1". These bolts have a sealant patch that will prevent leakage on the threads. This should be done before the Atlas is installed into the vehicle.
2. Install 1/2"-13 all-thread and jam nut to the shifter base.
3. Slide the shifter tower along the all-thread stud until the shifter arms are at the center of your stock floor cutout.
4. Measure between the tower and the base to obtain the correct extension tube length.
5. Remove the tower and install the extension tube.
6. Assemble the shift handles to the shift tower.
7. Install the shift tower assembly to the extension tube using the lock nut on 1/2"-13 all-thread to secure.
8. Install the brass shift rod ends to the Atlas shift rods. Teflon tape should be used on the threaded portion of the shift rod.
9. With the Atlas in neutral and the shift handles parallel with the shift tower, measure the distance for the linkage rods.
10. Connect the shift buttons and heat shrink tubing to the 3/8"-24 all-thread at the distance measured. Make sure that the all-thread is flush with the outside edge of the shift button. Cut all-thread if necessary.
11. Assemble the linkage rods to the shift handle and brass portion of the shift rod and verify the shift handles are parallel to the tower.
12. Install the e-clips to retain the buttons to the mating parts.
13. Make sure the brass shift rod ends are not too tight. They should be finger tight.
14. Modify the floorboard if necessary.
15. Install the rubber boot and boot ring to the floorboard. (Note: On some twin stick configurations, the boot ring may need to be cut in order to fit around the Atlas twin sticks).

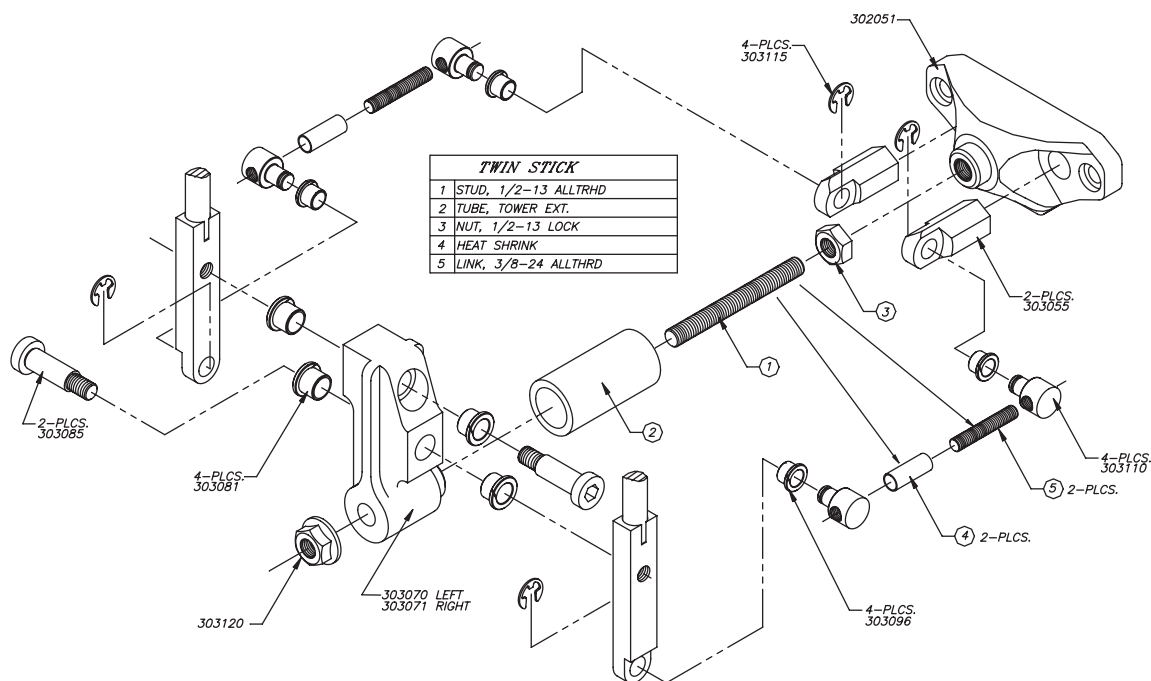

BRONCO ATLAS II SHIFTER

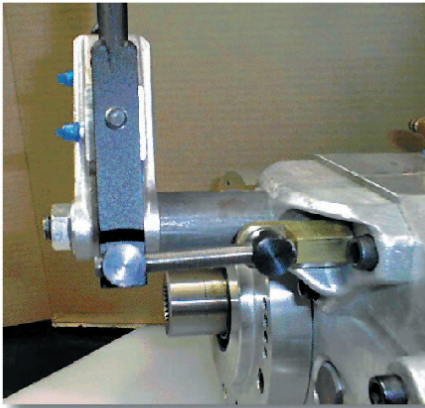
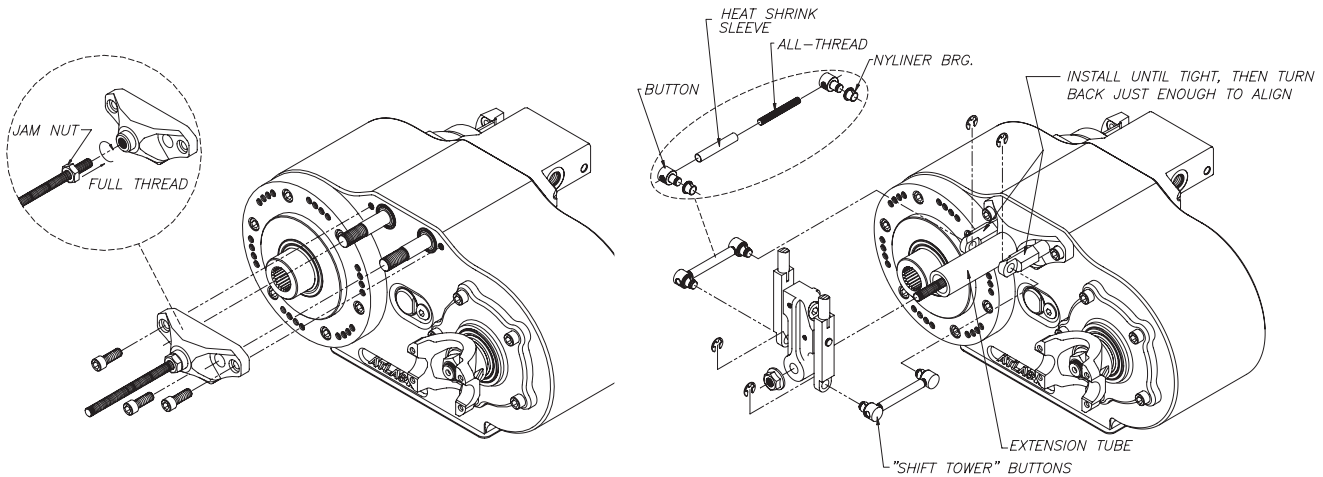

Atlas shifter problem check list: When installing the twin stick shifters, there are a few key areas that must be addressed. One of the most common difficulties we hear is that "my unit isn't shifting fully into one of the gear ratios". Incorrect adjustment of the shift handles to the linkage rods is normally the cause. With both shift rods in neutral, the linkage rod (connected to the shift handles) must be parallel with the aluminum shift tower. Refer to the photo left.

Another concern that we've heard is that "my Atlas seems to be hard to shift". This problem could be one of two areas. The brass shift rod ends that the shifter linkage rods connect to are too tight, causing a binding effect on the shifter linkage. The brass shift rod ends should be installed until tight, then loosened enough to align to the shifter button.

If a unit has a tendency to pop out of gear, an area to check is proper floorboard clearance in relation with the shift handles. This problem mainly occurs on Jeep TJs, since floorboard modifications are required. Most reported problems have been overcome by simply providing additional clearance. The problem of popping out of gear can also be caused by incorrect alignment of the shifter handles as previously discussed and/or a unit in which the detent set screws have been loosened.

The last of the most common dilemmas we hear is that "the shifter linkage came apart while in operation". The area in question is the all-thread linkage rods. These rods fit into the two shift buttons. To prevent the all-thread from unscrewing out of the shift buttons, a portion of the heat shrink tubing should have been installed (o-rings on a TJ automatic). The heat shrink tubing or o-rings act as a jam nut to prevent the all-thread from unscrewing. **DO NOT** use a jam nut on these linkage rods because it will cause binding of the shifter linkage.