



P.O. Box 247, 4320 Aerotech Center Way  
Paso Robles, CA 93447  
Telephone: (800) 350-2223 Fax: (805) 238-4201  
PAGE 1 OF 3 Page Rev. Date: 02-05-18  
P/N: 50-0211

## NEW VENTURE 4500 GM 5 SPEED TO TOYOTA L/C 10 SPLINE

### KIT CONSISTS OF:

No.	Qty.	Part No.	Description
1.	1	51-0224	ADAPTER CASTING 6.375" LONG
2.	1	52-0211A	10 SPLINE SPUD SHAFT (31T INTERNAL)
3.	1	716301	SEALED BEARING
4.	1	716199	BEARING SLEEVE FOR 716301 BEARING
5.	1	716462	SET COLLAR
6.	1	716507	GASKET
7.	8	720046	S.H.C.S. 10mm 1.5 THR x 40mm
8.	2	723735	3/8" FLAT WASHER
9.	2	723739	3/8"-16 x 7/8" H.H.C.S.
10.	5	724303	7/16" LOCKWASHERS
11.	8	724324	7/16" LOCKWASHERS, HIGH COLLAR
12.	3	724345	7/16"-14 x 5" HEX HD BOLT
13.	2	724349	7/16"-14 x 1-1/2" H.H.C.S.
14.	1	728701	NYLON NUT
15.	1	728702	7/8" FLATWASHER

### NOTE:

This adapter kit has an overall transmission assembled length of 18.750".

### CAUTION:

There are two 3/8" holes located on the side of the adapter for the mechanical shifter linkage. If your vehicle has a 3 speed vacuum type shifter, these holes are not going to be used. They will need to be plugged with the hardware provided and small amount of silicone. P/N715532 can be ordered if you have a mechanical linkage.

**SPECIAL NOTE:** The components packaged in this kit have been assembled and machined for specific type of conversions. Modifications to any of the components will void any possible warranty or return privileges. If you do not fully understand modifications or changes that will be required to complete your conversion, we strongly recommend that you contact our sales department for more information. This instruction sheet is only to be used for the assembly of Advance Adapter components. We recommend that a service manual pertaining to your vehicle be obtained for specific torque values, wiring diagrams and other related equipment. These manuals are normally available at automotive dealerships and parts stores.



P.O. Box 247, 4320 Aerotech Center Way  
Paso Robles, CA 93447  
Telephone: (800) 350-2223 Fax: (805) 238-4201  
PAGE 2 OF 3 Page Rev. Date: 02-05-18  
P/N: 50-0211

## NEW VENTURE 4500 GM 5 SPEED TO TOYOTA L/C 10 SPLINE

### NOTE:

1. This adapter is designed for exclusive use of the 4WD General Motors version of the New Venture Model 4500 transmission. You must use this transmission due to the length and spline size of the output shaft. The shaft must be shortened to the 4.498" cutoff length. In order to cut the shaft off, you will need to remove the tailhousing. The shaft can be cutoff using an abrasive cutoff saw or a skill saw equipped with a special metal cutting blade. Be sure to use safety glasses during this procedure. You must remove the harmonic balancer and install the 2 piece set collar.
2. The assembly of the adapter plate to the transfer case should be very much like the original transmission that is being replaced. A new flat washer and nut are provided for the early model vehicles to hold the two gears in position.
3. The alignment between the new adapter plate and transfer case must be performed by the new bearing that has been included with the adapter. This sealed bearing will have the external snap ring on the outside of the adapter similar to the original transmission. This will prevent the special transmission fluid of the New Venture gear box from mixing with the transfer case fluids.
4. When using this transmission assembly with a 6 cylinder Toyota engine, you may need to modify the gas tank area on 1979 and newer vehicles. It would be advisable that your vehicle be equipped with a suspension lift and you should plan on removal of the stock rear crossmember. A new Advance Adapter crossmember #716022-TSW, will be required. This transmission assembly is the very shortest possible and careful planning is a must when performing the installation with the stock 6 cylinder.
5. The transfer case shift controls will need to be modified for use with the new transmission. On 3 speed transfer case installations, they are usually equipped with a vacuum transfer case shifter control that does not require any additional brackets. If your installation is equipped with a mechanical linkage, then you will need bracket #715532. This may need some modifications in order to fit the 3 speed transfer case.

**SPECIAL NOTE:** The components packaged in this kit have been assembled and machined for specific type of conversions. Modifications to any of the components will void any possible warranty or return privileges. If you do not fully understand modifications or changes that will be required to complete your conversion, we strongly recommend that you contact our sales department for more information. This instruction sheet is only to be used for the assembly of Advance Adapter components. We recommend that a service manual pertaining to your vehicle be obtained for specific torque values, wiring diagrams and other related equipment. These manuals are normally available at automotive dealerships and parts stores.

## NEW VENTURE 4500 GM 5 SPEED TO TOYOTA L/C 10 SPLINE

TRANSMISSION ASSEMBLY O.A.L. = 18-3/4"

**NOTE:**

*This kit can only be used with GM 4WD New Venture 5 speed transmissions.*

This kit did use a 5.875" casting until July of 2014, the casting was changed for P/N 51-0214 to P/N 51-0224 and the spud shaft was lengthened .500". We still offer the old style shafts for the shorter castings.

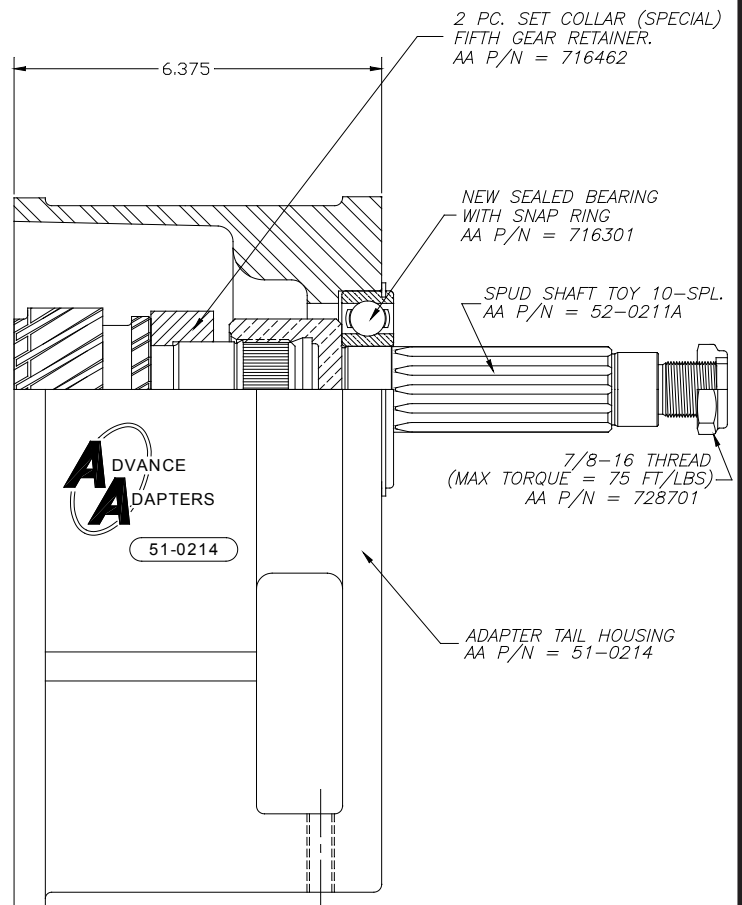
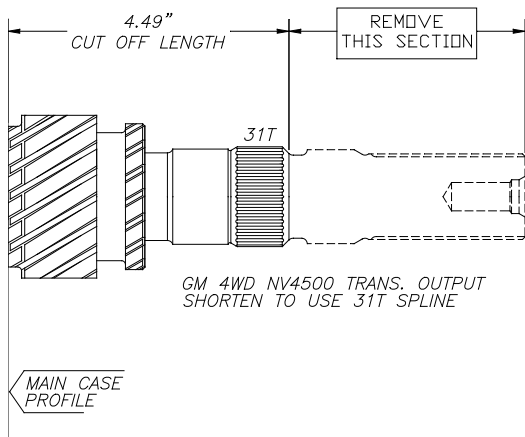

**SPECIAL NOTE:** The components packaged in this kit have been assembled and machined for specific type of conversions. Modifications to any of the components will void any possible warranty or return privileges. If you do not fully understand modifications or changes that will be required to complete your conversion, we strongly recommend that you contact our sales department for more information. This instruction sheet is only to be used for the assembly of Advance Adapter components. We recommend that a service manual pertaining to your vehicle be obtained for specific torque values, wiring diagrams and other related equipment. These manuals are normally available at automotive dealerships and parts stores.