

DODGE MODEL NV4500 5 SPEED 29 SPL OUTPUT TO TOYOTA L/C 19 SPLINE

KIT CONSISTS OF:

<i>No.</i>	<i>Qty</i>	<i>Part No.</i>	<i>Description</i>
1.	1	51-0224	ADAPTER CASTING
2.	1	52-0224	19 SPLINE SPUD SHAFT (29T INTERNAL)
3.	2	715539-1	SHIFT SPACER
4.	1	715539-2	SHIFT BRACKET
5.	1	716142	SPACER
6.	1	716247	BEARING RETAINER FOR 716310
7.	1	716317	308 BEARING
8.	1	716321	SPECIAL SNAP RING
9.	1	716758	DAUL LIP SEAL
10.	8	720046	10mm-1.5 x 40mm S.H.C.S.
11.	2	723704	LOCK WASHER 3/8" PLT
12.	2	723739	3/8"-16 x 7/8" H.H.C.S.
13.	7	724303	7/16" LOCKWASHERS
14.	3	724311	7/16"-14 x 3-1/2" H.H.C.S.
15.	4	724349	7/16"-14 x 1-1/2" H.H.C.S.
16.	1	724351	SET SCREW, 7/16"-14 x 1/2"

If your transfer case was coupled to a manual transmission, Toyota used a single lip seal in the front of the transfer case. The recommend changing the seal with a double lip seal P/N 716758 that was used on the stock automatic applications. Toyota # 90316-48003

NOTE:

This kit will work **ONLY** with Heavy Duty Dodge NV4500 5-speed transmissions.
NO EXCEPTIONS.

P/N 724351 must be installed (using silicone) into the casting as shown. This set screw will prevent fluid from leaking out of the casting.



CAUTION:

There are two 3/8" holes located on the side of the adapter for the mechanical shifter linkage. If your vehicle has a 3 speed vacuum type shifter, these holes are not going to be used. They will need to be plugged with the hardware provided and small amount of silicone.

SPECIAL NOTE: You may be required to change out the snap ring on the 308 bearing. The split-style transfer case used two different diameter snap ring groves in the case. We have included both snap rings to fit both styles of transfer cases.

SPECIAL NOTE: The components packaged in this kit have been assembled and machined for specific type of conversions. Modifications to any of the components will void any possible warranty or return privileges. If you do not fully understand modifications or changes that will be required to complete your conversion, we strongly recommend that you contact our sales department for more information. This instruction sheet is only to be used for the assembly of Advance Adapter components. We recommend that a service manual pertaining to your vehicle be obtained for specific torque values, wiring diagrams and other related equipment. These manuals are normally available at automotive dealerships and parts stores.



P.O. Box 247, 4320 Aerotech Center Way
Paso Robles, CA 93447
Telephone: (800) 350-2223 Fax: (805) 238-4201
PAGE 2 OF 3 Page Rev. Date: 02-05-18
P/N: 50-0224

DODGE MODEL NV4500 5 SPEED 29 SPL OUTPUT TO TOYOTA L/C 19 SPLINE

INSTALLATION NOTES:

1. This adapter is designed for exclusive use of the Dodge 4WD 29 spline output version of the NV Model 4500 transmission. You must use this transmission due to the length and spline size of the output shaft. The shaft must be shortened to the 5.420" cutoff length (see Page 3). In order to cut the shaft off, you will need to remove the tailhousing. The shaft can be cutoff using an abrasive cutoff saw or a skill saw equipped with a special metal cutting blade. Be sure to use safety glasses during this procedure.
2. The assembly of the adapter plate to the transfer case should be very much like the original transmission that is being replaced. The stock transfer case lock nut is retained to hold the two gears in position. The stock Toyota nut is P/N 90179-26004.
3. The alignment between the new adapter plate and transfer case must be performed by the new bearing that has been included with the adapter. This bearing will have the external snap ring on the outside of the adapter similar to the original transmission. **When installing the adapter to the NV4500 make sure the stock dowel pins are in the transmission.**
4. When using this transmission assembly with a 6 cylinder Toyota engine, you may need to modify the gas tank area on 1979 and newer vehicles. It would be advisable that your vehicle be equipped with a suspension lift. 1980 to 1985 vehicles require a custom crossmember to be made for the new transmission assembly. On 1986 & newer vehicles, the original crossmember can be modified.
5. The transfer case shift controls will need to be modified for use with the new transmission.

NOTE:

This casting is used for both the early and late Land Cruiser transfer cases. When bolting your transfer case to the new adapter, you will find one hole on the casting that is not used. We recommend using a dab of RTV Blue Silicone to plug this hole.

SPECIAL NOTE: The components packaged in this kit have been assembled and machined for specific type of conversions. Modifications to any of the components will void any possible warranty or return privileges. If you do not fully understand modifications or changes that will be required to complete your conversion, we strongly recommend that you contact our sales department for more information. This instruction sheet is only to be used for the assembly of Advance Adapter components. We recommend that a service manual pertaining to your vehicle be obtained for specific torque values, wiring diagrams and other related equipment. These manuals are normally available at automotive dealerships and parts stores.

DODGE MODEL NV4500 5 SPEED 29 SPL OUTPUT TO TOYOTA L/C 19 SPLINE

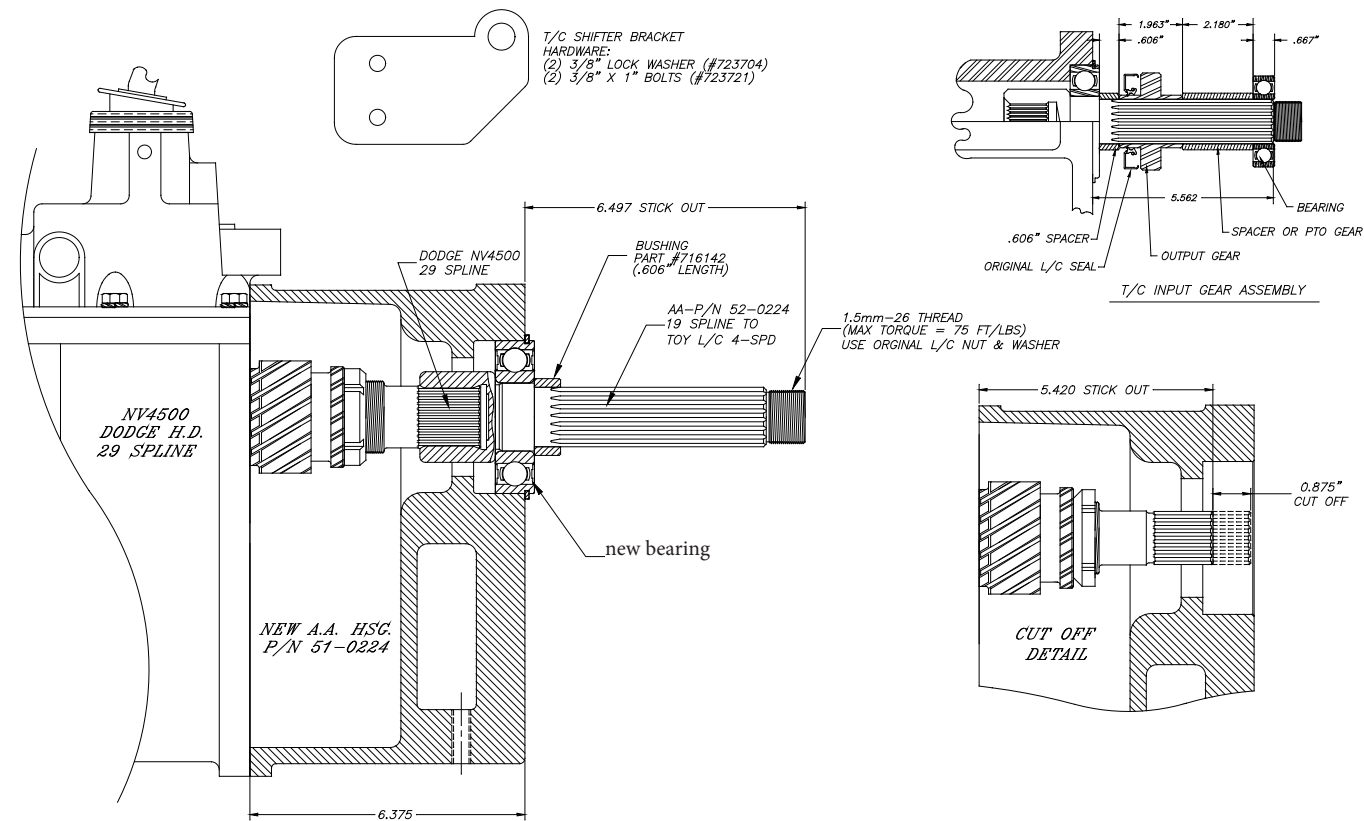

SPECIAL NOTE: The components packaged in this kit have been assembled and machined for specific type of conversions. Modifications to any of the components will void any possible warranty or return privileges. If you do not fully understand modifications or changes that will be required to complete your conversion, we strongly recommend that you contact our sales department for more information. This instruction sheet is only to be used for the assembly of Advance Adapter components. We recommend that a service manual pertaining to your vehicle be obtained for specific torque values, wiring diagrams and other related equipment. These manuals are normally available at automotive dealerships and parts stores.