

ADVANCE ADAPTERS INC.

P.O. Box 247, 4320 Aerotech Center Way
Paso Robles, CA 93447

Telephone: (800) 350-2223 Fax: (805) 238-4201

P/N: 50-5302

Old Part No: 711053-M
PAGE 1 OF 1

Page Rev. Date: 11-29-06

TH350 3 SPEED AUTOMATIC TO NP205 REPLACEMENT HOUSING

KIT CONSISTS OF:

<u>No.</u>	<u>Qty</u>	<u>Part No.</u>	<u>Description</u>
1.	1	51-5302	TH350 TO NP205 REPLACEMENT CASTING
2.	2	716745	NEW SEAL FOR ADAPTER HOUSING (<i>Installed by AA</i>)
3.	1	716511	"O"-RING
4.	1	716572	NP205 GASKET

INSTALLATION INSTRUCTIONS:

For GM vehicles 1971-1979 that were equipped with a TH350 transmission and a New Process 205 transfer case. This housing is a direct replacement for the stock cast iron housing. The stock housing was subject to breakage on the foot of the casting. We have provided two new seals and gaskets for installation of this replacement adapter.

There are two styles of this casting used from GM. One used a bearing supported coupler sleeve, and the second used a coupler sleeve that was centered by the male splines of the transfer case and transmission. The first couple of production runs of this casting were only machined to accept the second design from GM. Current production castings will accept either design of GM coupler.

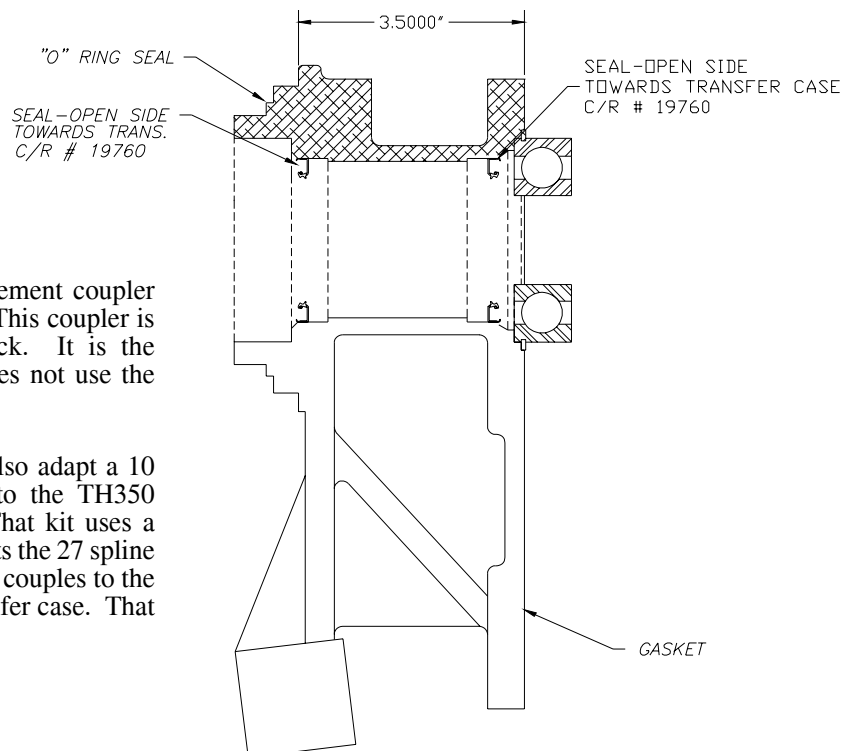

We do offer a replacement coupler under P/N 52-9503. This coupler is the same as the stock. It is the 'floating type' and does not use the support bearing.

In addition, we can also adapt a 10 spline transfer case to the TH350 using this casting. That kit uses a custom coupler that fits the 27 spline transmission and then couples to the 10 spline NP205 transfer case. That kit is P/N 50-5304.

SPECIAL NOTE: The components packaged in this kit have been assembled and machined for specific type of conversions. Modifications to any of the components will void any possible warranty or return privileges. If you do not fully understand modifications or changes that will be required to complete your conversion, we strongly recommend that you contact our sales department for more information. This instruction sheet is only to be used for the assembly of Advance Adapter components. We recommend that a service manual pertaining to your vehicle be obtained for specific torque values, wiring diagrams and other related equipment. These manuals are normally available at automotive dealerships and parts stores.