

## GM 4L60E ADAPTERS WITH A 4L60E SHAFT

**KIT CONSISTS OF:**

No.	Qty.	Part No.	Description
1.	1	51-0405	4L60E / UNIVERSAL ADAPTER
2.	1	300619	RELUCTOR SENSOR
3.	1	716079	22mm PLUG
4.	1	716074	RELUCTOR RING CLAMP RING
5.	4	720028	S.H.C.S. 10mm-1.5 x 35mm

**NOTE:** On Dana 300 transfer cases, you must use adapter Kit # 50-6309.

**Note:** We have found some Chevy Performance crate 4L70E transmissions have a larger diameter transmission output shaft where the VSS Tone Ring clamps on. If you encounter this please contact Advance Adapters as we have a modified reluctor to fit this shaft P/N 716074-70.

This kit was designed to adapt the 4L60E hex bolt pattern to any 700R adapter that Advance Adapters manufactures. **If your 4L60E has a square 4 bolt pattern, you will not need this kit. You already have the proper bolt pattern for using one of our kits.**

In 1996, GM produced a newer version of its electronically controlled 4L60E. This 4L60E transmission is 21-1/2" long, and has a removable bellhousing. It has a hex bolt pattern on the output side of the transmission, similar to a TH400.

The 50-0405E kit was designed to make this style of 4L60E look just like a 700R. By incorporating a new clamp-on reluctor ring and sensor on this adapter, a 40 pulse per output shaft revolution signal is generated for the drivetrain control module. This adapter comes with a new clamp-on reluctor ring that should be installed on the new 4L60E output shaft that you have had installed in your transmission. We have provided two reluctor sensor locations to choose from in the adapter. The hole not being used will need to be plugged with the plug provided.



Before tightening the clamp or set screws, trial fit the 51-0405 adapter plate onto the back of the 4L60E transmission. With the adapter set on the back of the transmission, install the 300619 reluctor sensor into the adapter casting. The 300619 sensor should line up over the teeth of the reluctor clamp. When you obtain this location, remove the adapter housing, making sure not to disturb the position of the clamp on the shaft. With the clamp now exposed, tighten the set screws on the clamp. *Loctite on these set screws is recommended.*

Trial fit the 51-0405 adapter and 300619 sensor back on the transmission and make sure the reluctor ring teeth and sensor still line up properly. *RTV Blue Silicone* should be used to seal the 51-0405 adapter to your 4L60E transmission. Screw the 300619 sensor completely into the 51-0405 casting. With a feeler gauge, check the gap between the sensor and the reluctor ring. This gap should be around 0.010" to 0.012". Once 0.010" to 0.012" clearance is obtained, loc-tite the sensor into position.

**SPECIAL NOTE:** The components packaged in this kit have been assembled and machined for specific types of conversions. Modifications to any of the components will void any possible warranty or return privileges. If you do not fully understand the modifications or changes that will be required to complete your conversion, we strongly recommend that you contact our sales department for more information. This Instruction Sheet is only to be used for the assembly of Advance Adapter components. We recommend that a service manual pertaining to your vehicle be obtained for specific torque values, wiring diagrams and other related equipment. These manuals are normally available at automotive dealerships and parts stores.

## GM 4L60E ADAPTERS WITH A 4L60E SHAFT

You are now ready to bolt your conversion adapter to the 51-0405 kit. **NOTE: On a few applications, customers have not positioned the clamp in the incorrect position which has caused interference with the spud shaft in the conversion adapter. If you try bolting the conversion adapter up to the 51-0405 and find interference, the spud shaft may be hitting the clamp on the reluctor.**

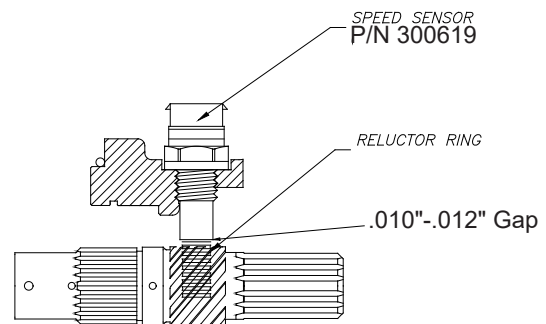
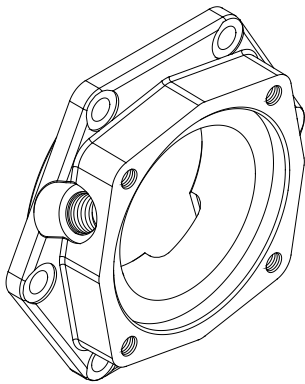

**Sensor note:** The sensor in this kit was changed in October 2005. This sensor will match up with the GM pigtail P/N 12162193 or Carquest P/N 57-4502 and NAPA, TSC200. The old sensor used in earlier kits matches up to GM pigtail P/N 12085498.

You will be required to do some modifications when using this kit with a stock GM TH350 cast iron adapter housing. The index hub on this casting protrudes too far from the bolting surface. This hub must be shortened approximately .625" to allow for the proper fit of our adapter kit. The power sleeve will also require shortening .250" on the transmission side on this sleeve. Adapters that used a bearing supported sleeve will be required to replace the sleeve with our P/N 52-9503B



**Warning Note:** Some adapter kits used in conjunction with this kit require an output shaft to be shortened. These kits are typically retaining a stock 2WD transmission output shaft. The measurement given for the proper cut off length on these adapter kits would normally be taken after the 50-0405 kit is installed onto your 4L60E transmission. Modifying a shaft without compensating for the 50-0405 kit will require a new output shaft to be installed.

**SPECIAL NOTE:** The components packaged in this kit have been assembled and machined for specific types of conversions. Modifications to any of the components will void any possible warranty or return privileges. If you do not fully understand the modifications or changes that will be required to complete your conversion, we strongly recommend that you contact our sales department for more information. This Instruction Sheet is only to be used for the assembly of Advance Adapter components. We recommend that a service manual pertaining to your vehicle be obtained for specific torque values, wiring diagrams and other related equipment. These manuals are normally available at automotive dealerships and parts stores.