

GM TH350 AUTO TO JEEP NP231 21 SPL. upgrade to a 95 and newer 23 SPL.

KIT CONSISTS OF:

No.	Qty	Part No.	Description
1.	1	51-6300	CASTING <i>(Assembled by AA)</i>
2.	1	52-1200	SHAFT
3.	1	52-6302	SPUD SHAFT <i>(Assembled by AA)</i>
4.	1 Pack	714201	BOLT PACK (50-6300)
5.	1	716062	NYLON BUSHING FOR T350 OUTPUT SHAFT <i>(CUSTOMER MUST INSTALL)</i>
6.	1	716095	23T NP231 T/C INPUT GEAR
7.	1	716308	BEARING (#6209) <i>(Assembled by AA)</i>
8.	1	716450	SNAP RING <i>(Assembled by AA)</i>
9.	1	716456	SNAP RING <i>(Assembled by AA)</i>
10.	1	716511	"O" RING
11.	1	716517	GASKET
12.	1	716738	NATIONAL SEAL (#473459) DUAL LIP
13.	6	723711	STUD BOLT 3/8"-16 X 2" LG.

OPTIONAL ITEMS:

Qty	Part No.	Description
1	716008	CROSSMBR . MOUNT
1	715523	T/C SHIFTER BRKT.



SPECIAL NOTE: The components packaged in this kit have been assembled and machined for a specific type of conversion. Modifications to any of the components will void any possible warranty or return privileges. If you do not fully understand the modifications or changes that will be required to complete your conversion, we strongly recommend that you contact our sales department for more information. This instruction sheet is only to be used for the assembly of Advance Adapter components. We recommend that a service manual pertaining to your vehicle be obtained for specific torque values, wiring diagrams and other related equipment. These manuals are normally available at automotive dealerships and parts stores. Always inspect parts prior to installation for consistency with the OEM offering (e.g., spline count, tooth count, lubrication points, etc.).



P.O. Box 247, 4320 Aerotech Center Way
Paso Robles, CA 93447
Telephone: (800) 350-2223 Fax: (805) 238-4201
PAGE 2 OF 5 Page Rev. Date: 08-08-19
P/N: 50-6305A

GM TH350 AUTO TO JEEP NP231 21 SPL. upgrade to a 95 and newer 23 SPL.

GM TH350 3 SPEED AUTOMATIC

The General Motors TH350 has a case length of 21-1/2", 13 bolts holding the oil pan in position and is available in two different engine to transmission bolt patterns. The case is available with a Chevy bolt pattern that has the top two holes 8-1/4" apart or a Buick bolt pattern that has the top two holes 7" apart. The rear side of the transmission case should have a square bolt pattern that uses 4 bolts. There are several various lengths of output shafts that these transmissions have been furnished with and you must make sure the proper shaft has been installed into the transmission for use with the Advance Adapter transfer case kit. We standardize our kits on the GM 4 wheel drive output shafts that were used in vehicles 1973-79. If the transmission you purchased had the correct output shaft, you can return the new output shaft for credit. All TH350 output shafts will have 27 splines. The speedometer gear is normally located in the tailhousing, but when adapting it to the transfer case, the location will change to the back side of the transfer case. The rear transmission support is located in the main case just forward of the tailhousing connection. This can be used for supporting the crossmember on some installations, but most of the Advance Adapter kits provide support on the new adapter housing.

When installing the new transfer case adapter, make sure that the coupler and the output shaft do not bottom out. We have found on occasion that a transmission output shaft may be slightly longer than we have allowed for; and when coupling into our new spud shaft, we find a small amount of interference. The adapter housing and spud shaft must be assembled to the back of the transmission without interference. **DO NOT FORCE THE NEW TAILHOUSING ONTO THE TRANSMISSION.** If assistance is needed, please feel free to call the number listed above.

When assembling the adapter housing to the transmission case, we have provided you with a new square-type "O" ring seal to prevent fluid leakage. This seal is a stock GM item that is used on all TH350 installations. Use silicone sealant on both surfaces of the transfer case gasket and Loctite all fasteners.

All installations will require the use of a transmission cooler. The cooler can be either installed in the radiator or a remote location is acceptable. The transmission shift control can either be a Hurst floor mounted type shifter or sometimes the existing column shift can be modified on certain applications.

INSTALLATION:

1. This kit includes a new output shaft for the TH350 which must be installed by an experienced transmission shop. We have provided a new nylon bushing for this shaft, which must also be install.
2. This kit comes pre-assembled with the bearing, snap rings, and spud shaft installed in the casting. The bearing and spud shaft are a press fit. The spud shaft is pressed to the bearing and the snap ring installed to retain the spud shaft properly. The bearing and spud shaft assembly are also a press fit into the adapter housing. The bearing and spud shaft are pressed into the casting. This assembly is retained with the provided snap ring.
3. Install the o-ring on the casting and use a small amount of silicone to provide a good seal. Bolt the adapter assembly to the TH350 transmission.
4. Using a thin film of silicone on both sides of the transfer case gasket, install the transfer case and gasket to the adapter assembly. The studs in the NP231 should locate the transfer case in the proper rotation.
5. The Advance Adapters crossmember mount will bolt to the bottom of the adapter casting. Mark and drill new holes in the skid plate to secure the transmission assembly to the skid plate.
6. Make sure all fasteners are secured and Loctite is used.

SPECIAL NOTE: The components packaged in this kit have been assembled and machined for a specific type of conversion. Modifications to any of the components will void any possible warranty or return privileges. If you do not fully understand the modifications or changes that will be required to complete your conversion, we strongly recommend that you contact our sales department for more information. This instruction sheet is only to be used for the assembly of Advance Adapter components. We recommend that a service manual pertaining to your vehicle be obtained for specific torque values, wiring diagrams and other related equipment. These manuals are normally available at automotive dealerships and parts stores. Always inspect parts prior to installation for consistency with the OEM offering (e.g., spline count, tooth count, lubrication points, etc.).

GM TH350 AUTO TO JEEP NP231 21 SPL. upgrade to a 95 and newer 23 SPL.

CAUTION!

Gasket positioning between the transfer case and new Advance Adapters housing is **CRITICAL**. If you fail to get the gasket in the proper location, oil seepage will occur. See photo for correct positioning.

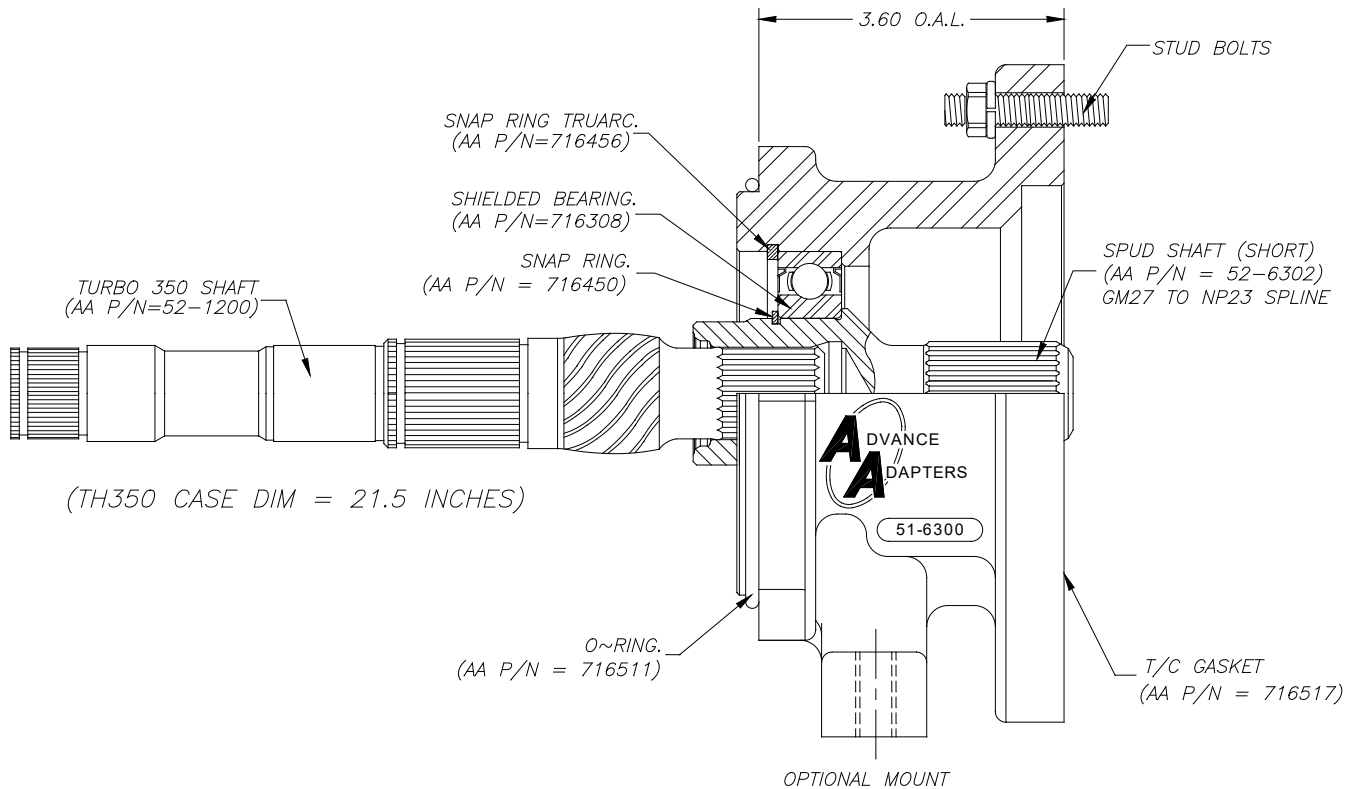

SPECIAL NOTE: The components packaged in this kit have been assembled and machined for a specific type of conversion. Modifications to any of the components will void any possible warranty or return privileges. If you do not fully understand the modifications or changes that will be required to complete your conversion, we strongly recommend that you contact our sales department for more information. This instruction sheet is only to be used for the assembly of Advance Adapter components. We recommend that a service manual pertaining to your vehicle be obtained for specific torque values, wiring diagrams and other related equipment. These manuals are normally available at automotive dealerships and parts stores. Always inspect parts prior to installation for consistency with the OEM offering (e.g., spline count, tooth count, lubrication points, etc.).

GM TH350 AUTO TO JEEP NP231 21 SPL. upgrade to a 95 and newer 23 SPL.

INSTRUCTIONS for NP 231 input gear:

This new input gear will only fit the NP231 transfer cases. The installation of the gear will require the complete disassembly of your NP231 transfer case. Since the transfer case has to be completely disassembled, this is also a good time to install a short output shaft kit (fixed yoke kit) if you already have not done so.

If you've never disassembled a New Process transfer case, here are a couple of points to keep in mind that will make the installation much easier:

1. Keep all bolts, nuts, washers, etc. separated into groups as you remove them. Make sure you keep them in a labeled container that indicates what part of the transfer case they came from.
2. Keep all small parts in separate containers and label as to location and origin.
3. Make sure you have plenty of time and have a clean, spacious area to perform the installation.

Remove the front yoke nut with a 1-1/8" socket using an impact wrench. Remove the rear case bolts. A 10mm 12 pt. socket is needed for the spline head bolt and a 15mm socket for the remaining bolts.

NOTE: The two black oxide finished bolts are located at the case dowel positions and require a washer under them. Start to remove the rear case from the front case by inserting pry bars at the cast-in locations **ONLY!** Pry apart evenly to break the sealer bead along the case mating surfaces. The front output shaft and chain should be retained with the rear portion of the case.



On the front side of the transfer case, you'll need to remove the 4 bolts that retain the aluminum bearing retainer. Once this is removed, you'll find a snap ring that retains the input gear to the cases' input bearing. This snap ring must be removed so that the input gear can be removed from the inside.



On the inside of the transfer case, you'll now be able to remove the planetary assembly. Set the assembly on a work bench and locate the snap ring that retains the input gear into the planetary housing. Remove the snap ring and lift the input gear out of the planetary housing.



SPECIAL NOTE: The components packaged in this kit have been assembled and machined for a specific type of conversion. Modifications to any of the components will void any possible warranty or return privileges. If you do not fully understand the modifications or changes that will be required to complete your conversion, we strongly recommend that you contact our sales department for more information. This instruction sheet is only to be used for the assembly of Advance Adapter components. We recommend that a service manual pertaining to your vehicle be obtained for specific torque values, wiring diagrams and other related equipment. These manuals are normally available at automotive dealerships and parts stores. Always inspect parts prior to installation for consistency with the OEM offering (e.g., spline count, tooth count, lubrication points, etc.).

GM TH350 AUTO TO JEEP NP231 21 SPL. upgrade to a 95 and newer 23 SPL.

Once the input gear is removed, you'll find a thrust washer that must be reinstalled onto the new 23 spline input. When comparing the two input gears, they should look the same except for the internal splines. If you find a difference between the two. The NP231 transfer case used two styles of front input bearings. The early transfer case used a wide bearing and the later model used a narrow bearing. This new input gear is designed for only the early style case. New Process changed the bearing and gear pitch design in 1995. The center photo below show a later model input compared to a early.

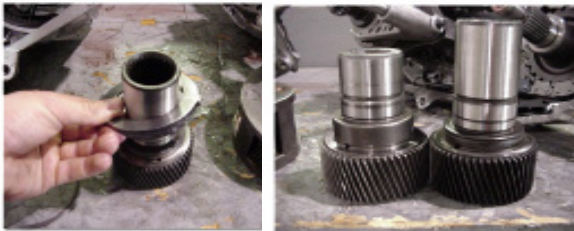

Once you have verified that you have the same style input gear, install the gear into the planetary, install the snap ring. Re-install the planetary assembly into the case and secure the input to the bearing with the front snap ring. **Note:** The only part you should have left out of the case is the old input gear. During reassembly, make sure the oil return hole matches the front retainer hole.

NOTE: This kit will not work
with a Tera low 4:1 NP231 kit.

SPECIAL NOTE: The components packaged in this kit have been assembled and machined for a specific type of conversion. Modifications to any of the components will void any possible warranty or return privileges. If you do not fully understand the modifications or changes that will be required to complete your conversion, we strongly recommend that you contact our sales department for more information. This instruction sheet is only to be used for the assembly of Advance Adapter components. We recommend that a service manual pertaining to your vehicle be obtained for specific torque values, wiring diagrams and other related equipment. These manuals are normally available at automotive dealerships and parts stores. Always inspect parts prior to installation for consistency with the OEM offering (e.g., spline count, tooth count, lubrication points, etc.).