

# ADVANCE ADAPTERS INC.

P.O. Box 247, 4320 Aerotech Center Way

Paso Robles, CA 93447

Telephone: (800) 350-2223 Fax: (805) 238-4201

# P/N: 713011

PAGE 1 OF 2

Page Rev. Date: 03-09-16

## BUICK 231 V6 UNIVERSAL ENGINE MOUNTS

### KIT CONSISTS OF:

No.	Qty	Part No.	Description
1.	1	713008-B	BOLT PACK RUBBER MOUNT KIT
2.	2	713012	ENGINE MOUNTING BRACKETS
3.	2	713045	FRAME BRACKETS
4.	2	713050	SLIDE LOCK TAB
5.	4	716656	RUBBER MOUNT
5.	4	724302	7/16" FLAT WASHER
6.	4	724303	7/16" LOCK WASHER
7.	4	724307	H.H.C.S. 7/16"-14 x 1" (Grade 5)
8.	2	725042	BOLT-1/2"-13 x 1 CGE GRADE 5 ZINC
9.	2	303120	Serrated-Flange Hex Locknut 1/2 - 13 zinc

**NOTE:** For frame rails wider than 26 inches, we offer a different set of frame brackets that will fit frame rail widths up to 29". Replace P/N 713045 with P/N 713037.

### INSTALLATION INSTRUCTIONS:

These Universal engine mounts are designed for use on all types of 4WD and 2WD vehicles that have frame rail widths up to 26". The frame brackets can be used either facing upward or facing downward to achieve the best engine position location. The brackets **must be** welded but can be bolted into position so the vehicle can be taken to a welding shop. If you are dealing with a vehicle that has an open channel, then you should box in the frame rail prior to mounting the new bracket. The slots of the mounts are designed to give you side to side adjustments. The slide lock tab will lock the mount down once the engine location is selected. The slide lock tab does require welding to the engine bracket but should be bolted to secure for assembly purposes, this can allow you can transport your rig to your local welder.

On CJ Jeep and Toyota conversions, it is best to offset the engine 1" towards the driver's side and on Jeep YJ's 1" to the passengers side. The height and lateral location of the motor is determined by the placement of the frame brackets. When trial fitting the motor into the chassis, the final position should take into consideration the following items.

1. Firewall clearance
2. Oil pan & Pulley clearance
3. Hood clearance
4. Radiator & fan allowance
5. Steering box and/or linkage clearance
6. Header/exhaust manifold clearance
7. Distributor accessibility
8. Starter motor clearance on front driveline

The engine mounts are adjustable for frame widths from 20.50" to 26.00". The adjustable slots allow you to move the engine from one side or the other to allow for the above mentioned clearances. When the mounts are adjusted to the minimum or maximum widths, the slide function does not work as you are at the limits of the mounts.

When fitting these mounts into the vehicle, we recommend bolting the complete mount assembly to the engine block. Measure your frame width and set the frame brackets at a width just under that. As you lower the block into the frame rails and find the proper height and front-to-rear location, clamp the frame bracket to the frame rail. Once the brackets are clamped, you can then adjust side-to-side on the mounts. If all looks good for clearances, make sure the frame brackets are clamped secure to the frame and install the carriage bolt through the second hole on the slide lock tab and firmly secure it with the flanged nut. The square portion of the carriage bolt will stake the tab and secure it to the mount. This will allow you to disassemble the rubber mounts from the block to leave the frame perch in the correct location for welding as well as secure the hole location on the slide lock.

The frame bracket needs to be welded to the frame, and the slide lock tab needs two 1/2" or longer welds at both ends to secure the tab to the block mount. This will secure the block to the frame bracket, not allowing any side movement once the desired location is chosen.

**SPECIAL NOTE:** The components packaged in this kit have been assembled and machined for specific type of conversions. Modifications to any of the components will void any possible warranty or return privileges. If you do not fully understand modifications or changes that will be required to complete your conversion, we strongly recommend that you contact our sales department for more information. This instruction sheet is only to be used for the assembly of Advance Adapter components. We recommend that a service manual pertaining to your vehicle be obtained for specific torque values, wiring diagrams and other related equipment. These manuals are normally available at automotive dealerships and parts stores.

# ADVANCE ADAPTERS INC.

P.O. Box 247, 4320 Aerotech Center Way

Paso Robles, CA 93447

Telephone: (800) 350-2223 Fax: (805) 238-4201

# P/N: 713011

PAGE 2 OF 2

Page Rev. Date: 09-09-15

## BUICK 231 V6 UNIVERSAL ENGINE MOUNTS



The mount can be assembled with the rubber mounts on the inner slot for a narrow frame or the outer slots for a wider frame. When the engine location is selected, tighten the carriage bolt to secure the mount location and then weld two 1/2" or more beads to secure the slide lock tab.

Clamp the frame bracket to the frame rail to check clearance before welding mounts into position.

**THE 5/8"-18 NYLON NUT SHOULD BE TORQUED TO 25 TO 30 FT./LBS.**

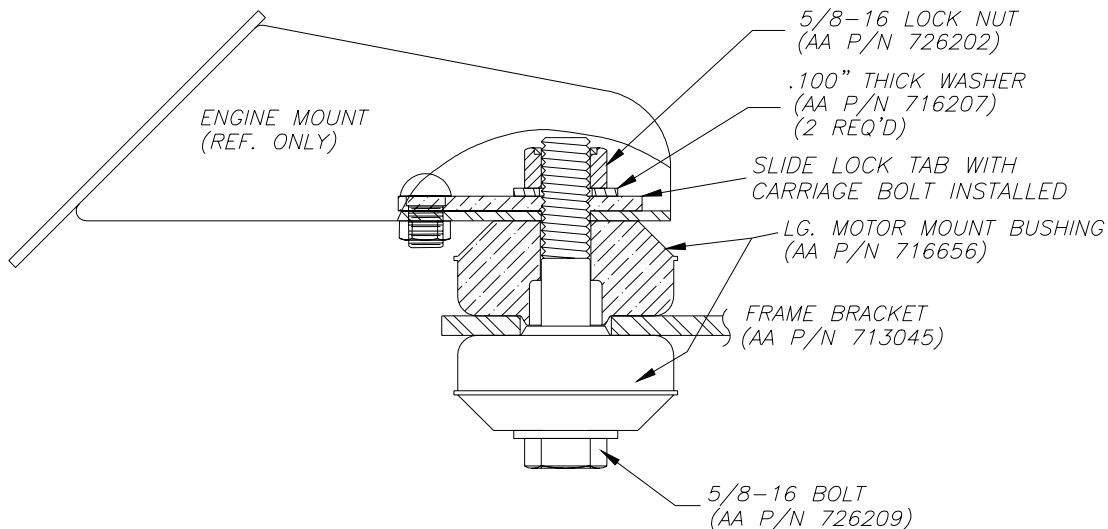

**SPECIAL NOTE:** The components packaged in this kit have been assembled and machined for specific type of conversions. Modifications to any of the components will void any possible warranty or return privileges. If you do not fully understand modifications or changes that will be required to complete your conversion, we strongly recommend that you contact our sales department for more information. This instruction sheet is only to be used for the assembly of Advance Adapter components. We recommend that a service manual pertaining to your vehicle be obtained for specific torque values, wiring diagrams and other related equipment. These manuals are normally available at automotive dealerships and parts stores.