

GM 4L60E AUTOMATIC O.D. TO LAND CRUISERS 1980-89 FJ60 (4 SPEED)

KIT CONSISTS OF:

No.	Qty	Part No.	Description
1.	1	51-8900	CASTING (<i>with sensor drilled</i>) (Ref: 711189)
2.	1	52-8300	SPUD SHAFT WITH 19 SPLINES (Ref: 711383)
3.	1	300619	SENSOR
4.	1	715547	TRANSFER CASE SHIFTER BRKT.
5.	3	715548	TRANSFER CASE BRKT. SPACERS
6.	1	716142	BUSHING/GEAR LOCATER
7.	1	716317	308 BEARING
8.	1	716321	SPECIAL SNAP RING FOR 716310 BEARING
9.	1	716511	"O"-RING
10.	1	716571	GASKET
11.	1	716758	TRANSFER CASE FRONT INPUT SEAL 90316-48003
12.	3	720062	12mm-1.25 x 90mm LONG H.H.C.S. (<i>transfer case to adapter housing bolts</i>)
13.	4	720063	12mm-1.25 x 40mm LONG H.H.C.S. (<i>transfer case to adapter housing bolts</i>)
14.	1	*720090	12mm-1.25 SET SCREW (INSTALLED BY AA)
15.	3	723734	3/8"-16 x 2-1/2" S.H.C.S.
16.	7	724302	FLAT WASHER
17.	1	728703	26mm - 1.5 SHAFT NUT

SPECIAL NOTE: You may be required to change out the snap ring on the 308 bearing. The split-style transfer case used two different diameter snap ring groves in the case. We have included both snap rings to fit both styles of transfer cases.

If your transfer case was coupled to a manual transmission, Toyota used a single lip seal in the front of the transfer case. The recommend changing the seal with a double lip seal P/N 716758 that was used on the stock automatic applications. Toyota # 90316-48003

NOTE: THIS KIT USES A 2WD 4L60E OUTPUT SHAFT (O.A.L. 18-3/16").

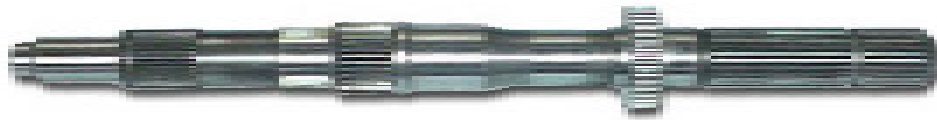

NOTE: This kit requires the 2WD output shaft to be shortened. If you are using this kit on a newer hex bolt pattern 4L60E transmission, then you will be required to use our 51-0405 adapter housing. Please note that the cut off location on the output shaft must be made after this adapter is installed on the transmission. This 51-0405 adapter make the hex pattern 4L60E transmission look just like the square bolt pattern transmission, and the cut off location for the output shaft is shown on this instruction sheet is for the square bolt pattern transmission.

SPECIAL NOTE: The components packaged in this kit have been assembled and machined for specific type of conversions. Modifications to any of the components will void any possible warranty or return privileges. If you do not fully understand modifications or changes that will be required to complete your conversion, we strongly recommend that you contact our sales department for more information. This instruction sheet is only to be used for the assembly of Advance Adapter components. We recommend that a service manual pertaining to your vehicle be obtained for specific torque values, wiring diagrams and other related equipment. These manuals are normally available at automotive dealerships and parts stores.



P.O. Box 247, 4320 Aerotech Center Way
Paso Robles, CA 93447
Telephone: (800) 350-2223 Fax: (805) 238-4201
PAGE 2 OF 4 Page Rev. Date: 10-09-17
P/N: 50-0408

GM 4L60E AUTOMATIC O.D. TO LAND CRUISERS 1980-89 FJ60 (4 SPEED)

INSTALLATION INSTRUCTIONS

This kit is for the GM 4L60 4 speed automatics to all Toyota Land Cruiser split-type transfer cases. The design of this kit utilizes two shafts. The first shaft is your 4L60 output shaft that is cutoff to the length illustrated on page 3. With the shaft cut to the proper length, the new Advance Adapter spud shaft can now be put into position. The new spud shaft should be pressed into the new rear bearing so the external snap ring is towards the threaded end of the shaft. With the bearing on the spud shaft, you can now install the assembly into the back portion of the adapter. The external snap ring will lock the spud shaft into position. A special heat-treated gear spacer has been provided for determining the exact gear location. Before installing the spacer on the spud shaft, we recommend applying some RTV silicone on the spline portion of the spud shaft that this spacer covers. This will prevent any fluid transfer between the two gear boxes. The threaded portion on the end of the spud shaft will be identical to the 4 speed transmission being replaced. The original gears, bearing, washer and nut will all be reused onto the new spud shaft. **The stock transfer case lock nut is Toyota P/N 90179-26004.** The transfer case indexes to the adapter off the new rear bearing and we also use the lower dowel pin on the transfer case. The upper dowel pin is not used and our casting hole has been over sized to fit over the stock dowel pin location. The bearing give the proper indexing and the lower dowel provides the proper rotation.

On the right side of the adapter, you will be able to mount the special shift bracket illustrated on page 4. This bracket should position your shifter in the original floor board location. On FJ60 vehicles that are installing the Chevy V8 engine using the 4L60 transmission, you should be able to leave the transfer case in its original position. The bottom of the transfer case adapter has a support mount that is identical to the support that was previously used on the bottom of the 4 speed transmission. The original crossmember support will need to be repositioned directly beneath the new transfer case adapter housing.

GM 4L60 4 SPEED AUTOMATIC:

When installing the new transfer case adapter, make sure that the coupler and the output shaft do not bottom out. We have found on occasion that a transmission output shaft may be slightly longer than we have allowed for and when coupling into our new spud shaft, we find a small amount of interference. The adapter housing and spud shaft must be assembled to the back of the transmission without interference. **DO NOT FORCE THE NEW TAILHOUSING ONTO THE TRANSMISSION.** If assistance is needed, please feel free to call us toll free number at 1-800-350-2223.

When assembling the adapter housing to the transmission case, we have provided you with a new square type "O"-ring seal to prevent fluid leakage. This seal is a stock GM item that is used on all 4L60 installations. On most installations, a slight pan modification may be required for clearance of the front Universal yoke.

The Advance Adapter casting has been drilled for your new sensor. The sensor should be installed and the gap between the sensor and the ring should be .010" to .012" air gap.

CROSSMEMBER NOTE:

This casting is designed around the FJ60 manual transmission crossmember mount. On some manual applications and all automatic stock transmissions, you may need to purchase Toyota #12371-61020. This part is the new Toyota rubber mount.

SPECIAL NOTE: The components packaged in this kit have been assembled and machined for specific type of conversions. Modifications to any of the components will void any possible warranty or return privileges. If you do not fully understand modifications or changes that will be required to complete your conversion, we strongly recommend that you contact our sales department for more information. This instruction sheet is only to be used for the assembly of Advance Adapter components. We recommend that a service manual pertaining to your vehicle be obtained for specific torque values, wiring diagrams and other related equipment. These manuals are normally available at automotive dealerships and parts stores.

GM 4L60E AUTOMATIC O.D. TO LAND CRUISERS 1980-89 FJ60 (4 SPEED)

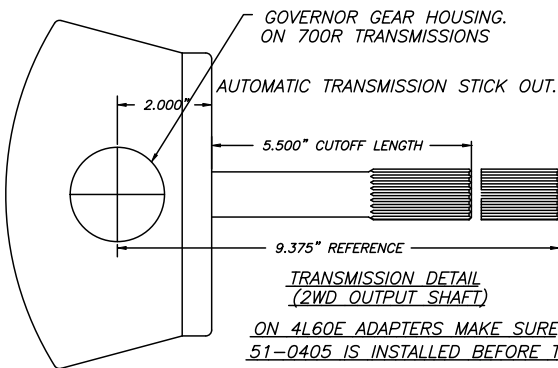

TRANSMISSION DETAIL (2WD OUTPUT SHAFT)

ON 4L60E ADAPTERS MAKE SURE 51-0405 IS INSTALLED BEFORE TAKING THE MEASUREMENT

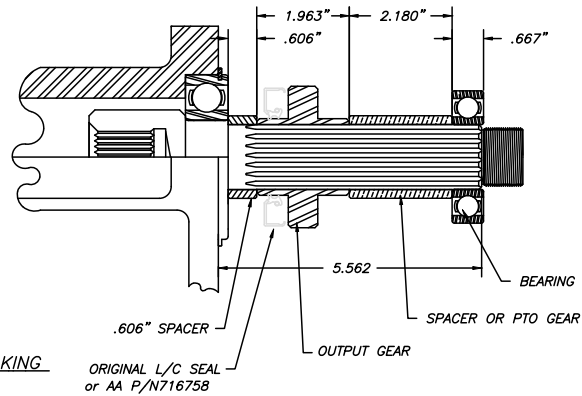

T/C INPUT GEAR ASSEMBLY

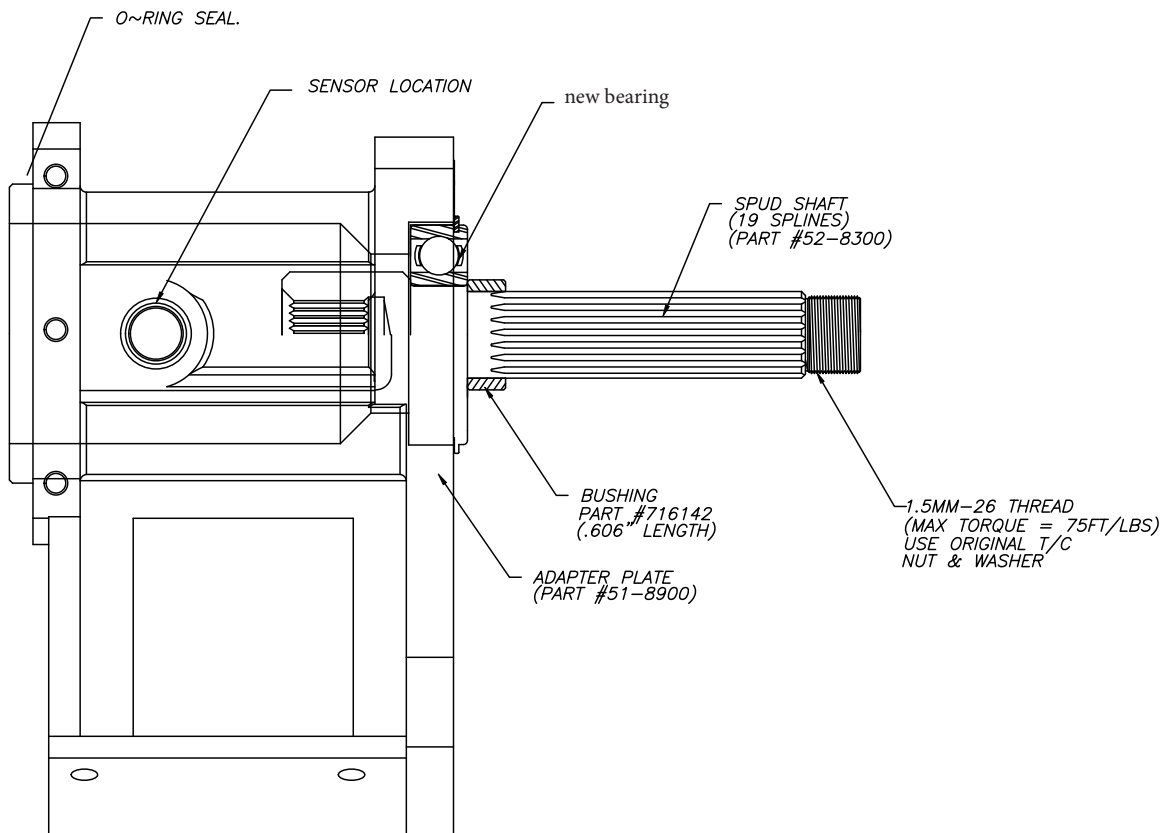

SPECIAL NOTE: The components packaged in this kit have been assembled and machined for specific type of conversions. Modifications to any of the components will void any possible warranty or return privileges. If you do not fully understand modifications or changes that will be required to complete your conversion, we strongly recommend that you contact our sales department for more information. This instruction sheet is only to be used for the assembly of Advance Adapter components. We recommend that a service manual pertaining to your vehicle be obtained for specific torque values, wiring diagrams and other related equipment. These manuals are normally available at automotive dealerships and parts stores.



P.O. Box 247, 4320 Aerotech Center Way
Paso Robles, CA 93447
Telephone: (800) 350-2223 Fax: (805) 238-4201
PAGE 4 OF 4 Page Rev. Date: 10-09-17
P/N: 50-0408

GM 4L60E AUTOMATIC O.D. TO LAND CRUISERS 1980-89 FJ60 (4 SPEED)

Vehicles that were equipped originally with a manual transmission used a sleeve that locates the gear for the transmission rear bearing and provides a seal surface. These applications do not require the use of our spacer P/N 716142. You must retain this stock gear spacer on these applications. All other vehicles have the seal surface on the gear and will need to use the gear spacer included in this kit.

SPECIAL NOTE: The components packaged in this kit have been assembled and machined for specific type of conversions. Modifications to any of the components will void any possible warranty or return privileges. If you do not fully understand modifications or changes that will be required to complete your conversion, we strongly recommend that you contact our sales department for more information. This instruction sheet is only to be used for the assembly of Advance Adapter components. We recommend that a service manual pertaining to your vehicle be obtained for specific torque values, wiring diagrams and other related equipment. These manuals are normally available at automotive dealerships and parts stores.