

## ***BELLHSG. FOR JEEP 4.0 & V8 304 ENG. TO NV4500 & GM SM465 TRUCK 4 SPEEDS***

**KIT CONSISTS OF:**

<b>No.</b>	<b>Qty</b>	<b>Part No.</b>	<b>Description</b>
1.	1	712571-BLK	5-1/8" DIA. BELLHOUSING
2.	1	716109	3/4" SOFT PLUG
3.	1	716156-GM	PILOT BUSHING W/ .590" I.D.
4.	1	716176	CLUTCH RELEASE ARM
5.	1	716176SC	GM THROW-OUT LEVER SPRING CLIP
6.	1	716180	BALL PIVOT
7.	1	716332	CLUTCH LEVER BOOT ( <b>see NOTE below</b> )
8.	2	723134	H.H.C.S. 5/16"-18 x 1-1/4" LG. ( <i>Slave Cylinder</i> )
9.	4	724303	7/16" LOCK WASHERS
10.	4	724328	H.H.C.S. 7/16"-14 x 1-1/4" LG. ( <i>TRANS</i> )

***NOTE:*** The throw out arm boot provided in this bellhousing kit was designed for a Jeep throw out arm. The arm provided in this kit is a Chevrolet arm. The boot may need to be modified for the correct arm location in the boot.

***NOTE:*** The 4.0L blocks replacing a manual transmission used a 2 piece pilot bushing. Both pieces must be removed, the bearing and the sleeve. If these pieces are not removed, the new brass pilot bushing will not fit. We do not offer a smaller pilot bushing to fit the reducer sleeve. On 4.0L that were originally mated to a automatic the new pilot bushing will fit without any modifications.

The new pivot ball needs to be installed into the bellhousing. Apply blue Loctite to the threads and torque to 40-45 ft-lbs. The clutch fork will need the spring clip installed; a pair of needle nose pliers works well. Once the spring clip is installed, apply grease to the spring and socket of the fork.

\*Note: Clutch fork must be installed into the bellhousing before bolting to the engine.

Place the fork over the pivot ball, centering the spring clip. With a dead blow hammer, hit the back side of the fork using ample force, directly perpendicular to the pivot ball ( 2 or 3 times may be required). Fork should move free, with slight resistance. If not, repeat the force with the dead blow hammer.

See photo



**SPECIAL NOTE:** The components packaged in this kit have been assembled and machined for specific type of conversions. Modifications to any of the components will void any possible warranty or return privileges. If you do not fully understand modifications or changes that will be required to complete your conversion, we strongly recommend that you contact our sales department for more information. This instruction sheet is only to be used for the assembly of Advance Adapter components. We recommend that a service manual pertaining to your vehicle be obtained for specific torque values, wiring diagrams and other related equipment. These manuals are normally available at automotive dealerships and parts stores.

## BELLHSG. FOR JEEP 4.0 & V8 304 ENG. TO NV4500 & GM SM465 TRUCK 4 SPEEDS

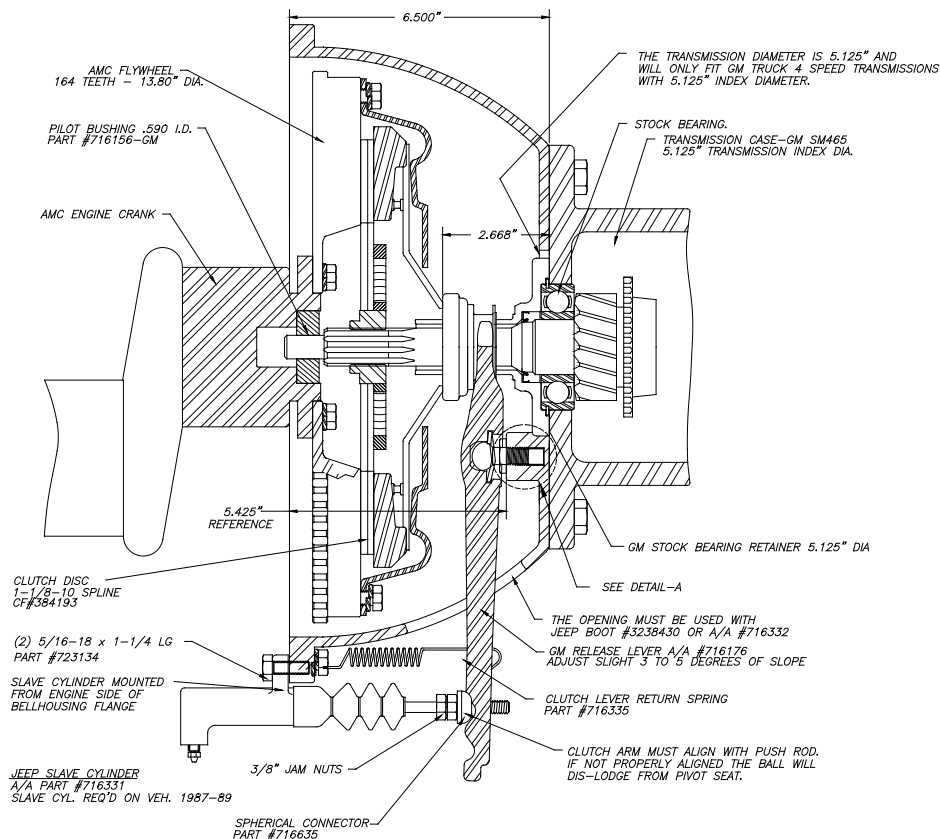

**SPECIAL NOTE:** The components packaged in this kit have been assembled and machined for specific type of conversions. Modifications to any of the components will void any possible warranty or return privileges. If you do not fully understand modifications or changes that will be required to complete your conversion, we strongly recommend that you contact our sales department for more information. This instruction sheet is only to be used for the assembly of Advance Adapter components. We recommend that a service manual pertaining to your vehicle be obtained for specific torque values, wiring diagrams and other related equipment. These manuals are normally available at automotive dealerships and parts stores.

## **BELLHSG. FOR JEEP 4.0 & V8 304 ENG. TO NV4500 & GM SM465 TRUCK 4 SPEEDS**

**Note:**

2005 & Newer 4.0L engines use a new location and style of crank position sensor. Shown in photo below is the newer CPS location. If your engine is pre-2005, please plug this hole with the 3/4" soft plug that has been provided. Plug will need to be pressed or tapped in using a dowel and soft hammer.

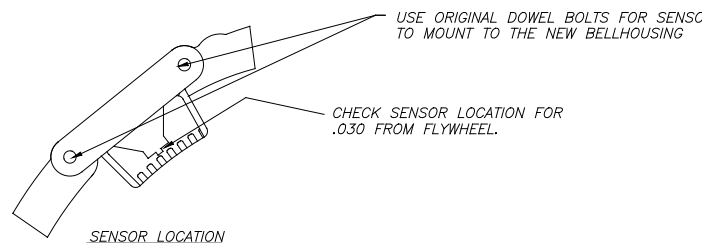
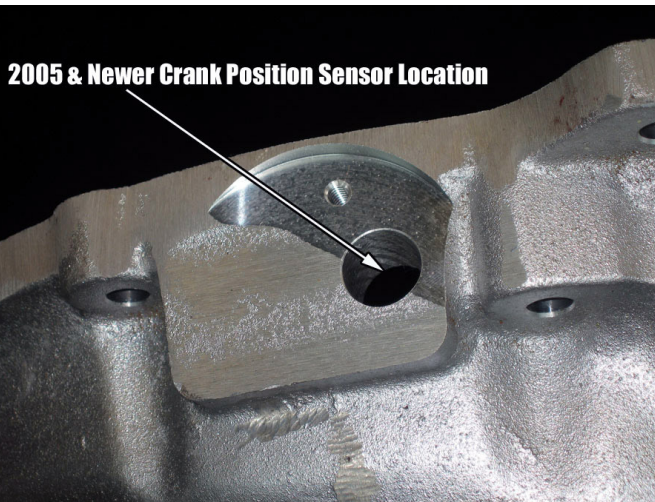

**SPECIAL NOTE:** The components packaged in this kit have been assembled and machined for specific type of conversions. Modifications to any of the components will void any possible warranty or return privileges. If you do not fully understand modifications or changes that will be required to complete your conversion, we strongly recommend that you contact our sales department for more information. This instruction sheet is only to be used for the assembly of Advance Adapter components. We recommend that a service manual pertaining to your vehicle be obtained for specific torque values, wiring diagrams and other related equipment. These manuals are normally available at automotive dealerships and parts stores.



P.O. Box 247, 4320 Aerotech Center Way  
Paso Robles, CA 93447  
Telephone: (800) 350-2223 Fax: (805) 238-4201  
PAGE 4 OF 6 Page Rev. Date: 8-08-18  
P/N: 712571

## **BELLHSG. FOR JEEP 4.0 & V8 304 ENG. TO NV4500 & GM SM465 TRUCK 4 SPEEDS**

### **INSTALLATION INSTRUCTIONS:**

Depending on the year of the vehicle that you are dealing with, you will need to vary the clutch control requirements accordingly. The bellhousing that we have manufactured will use a GM clutch release arm along with a GM clutch release bearing. Since you are using a GM transmission, the N1430 release bearing and GM clutch release arm will work perfectly without any modifications. The new GM clutch arm will have an internal snap ring to lock onto the ball pivot stud inside the new bellhousing. On Jeep vehicles that were originally equipped with a mechanical clutch control, you should not have any problem adapting your original clutch linkage to the new clutch arm. On Jeep vehicles that were previously equipped with a hydraulic slave cylinder such as 1987-2005 and 1980-1986 four cylinders, you will need to use a Jeep slave cylinder that was used in the 1980-1983 Iron Duke four cylinder Jeep vehicles. We offer this Jeep clutch control slave cylinder kit as Part No. 716331. This new assembly will include all the necessary parts to mount to the new bellhousing.

The bellhousing is a direct duplicate of the original AMC stock bellhousing. The flywheel sensor, dowel pin holes and dust cover mounting holes are all in the original location. The original dust cover or block plate must be retained for use with the Advance Adapter bellhousing. This plate is normally already on the engine block. The flywheel sensor must be installed onto the new bellhousing using the original bolts. The factory dowel bolts provide the necessary accuracy to mount the sensor in the appropriate location.

Your new SM465 OR NV4500 transmission will require a new pilot bushing for the engine crank and possibly a new clutch disc. The new transmission will require a Chevy clutch disc with a 1-1/8"-10 spline size Centerforce No. 384193. It is advisable that you check the input shaft tip engagement into the new pilot bearing after installation. **DO NOT FORCE THE TRANSMISSION INTO POSITION.** The flywheel must be 1" thick. We have seen some flywheels up to 1.5" thick, which can cause interference problems. This 1" measurement should be taken from the crank flange to the clutch disc surface. This bellhousing also requires the use of a diaphragm pressure plate. Most Borg & Beck 3 finger pressure plates will not work.

Prior to assembling the bellhousing onto the engine, you will need to install the clutch ball pivot. We have provided two (2) different locations depending on the year of the vehicle that the bellhousing is being installed into. The upper location will be for Wrangler hydraulic clutch controls, while of the lower location will be for mechanical clutch type controls. Refer to **Page 6** for additional information.

**CAUTION:** *On some of the early installations, we have encountered an interference problem between the clutch pressure plate and clutch release arm. The solution is to grind the necessary clearance on the inside of the bellhousing and modify the release lever approximately 1/16". It will be necessary for you to check the clutch clearance inside the bellhousing prior to transmission assembly. This problem has only occurred with aftermarket clutch assemblies or thicker than normal flywheels*

### **SM420 AND SM465 SHIFT TOWER CLEARANCES:**

The new bellhousing will allow for the Chevy transmission to bolt directly against the face. There are a few transmissions that have the top shifter cover over lapping the face of the transmission. If your transmission has this slight over lap, it will be necessary to grind a small relief on either the top shifter or bellhousing area.

**SPECIAL NOTE:** The components packaged in this kit have been assembled and machined for specific type of conversions. Modifications to any of the components will void any possible warranty or return privileges. If you do not fully understand modifications or changes that will be required to complete your conversion, we strongly recommend that you contact our sales department for more information. This instruction sheet is only to be used for the assembly of Advance Adapter components. We recommend that a service manual pertaining to your vehicle be obtained for specific torque values, wiring diagrams and other related equipment. These manuals are normally available at automotive dealerships and parts stores.

## BELLHSG. FOR JEEP 4.0 & V8 304 ENG. TO NV4500 & GM SM465 TRUCK 4 SPEEDS

**\*NOTE: THE LOWER DUST COVER MUST BE MODIFIED ACCORDINGLY BEFORE INSTALLATION OF SLAVE CYLINDER. SLAVE CYLINDER SHOULD BE INSTALLED TO TOP OF DUST COVER.**

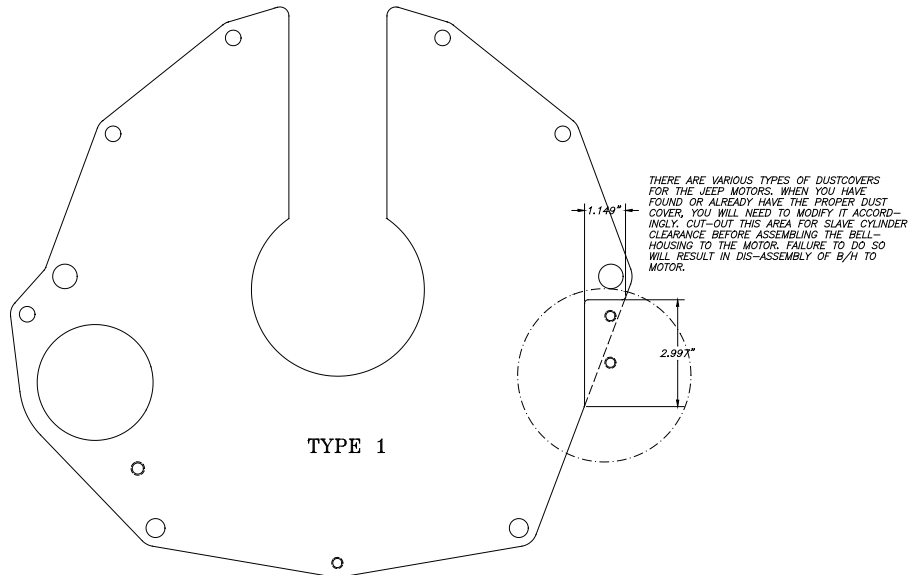

TYPE 1

(2) HOLES TO BE ELONGATED AS SHOWN.

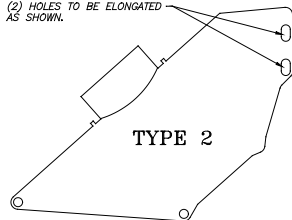

TYPE 2

LOWER SECTION OF TWO PIECE DUST COVER

\*NOTE:  
THE LOWER DUST COVER MUST BE MODIFIED ACCORDINGLY BEFORE INSTALLATION OF SLAVE CYLINDER. SLAVE CYLINDER SHOULD BE INSTALLED TO TOP OF DUST COVER.

**SPECIAL NOTE:** The components packaged in this kit have been assembled and machined for specific type of conversions. Modifications to any of the components will void any possible warranty or return privileges. If you do not fully understand modifications or changes that will be required to complete your conversion, we strongly recommend that you contact our sales department for more information. This instruction sheet is only to be used for the assembly of Advance Adapter components. We recommend that a service manual pertaining to your vehicle be obtained for specific torque values, wiring diagrams and other related equipment. These manuals are normally available at automotive dealerships and parts stores.

**BELLHSG. FOR JEEP 4.0 & V8 304 ENG.  
TO NV4500 & GM SM465 TRUCK 4 SPEEDS**

TOP

THIS UPPER LOCATION IS  
FOR JEEP WRANGLERS -  
1987 TO CURRENT  
"HYDRAULIC CLUTCH"  
DRIVELINE ON DRIVERSIDE

THIS LOWER LOCATION IS  
FOR JEEPS CJ5-CJ7 -  
1972 TO 1986  
"MECHANICAL CLUTCH" DRIVELINE ON  
PASSENGER SIDE

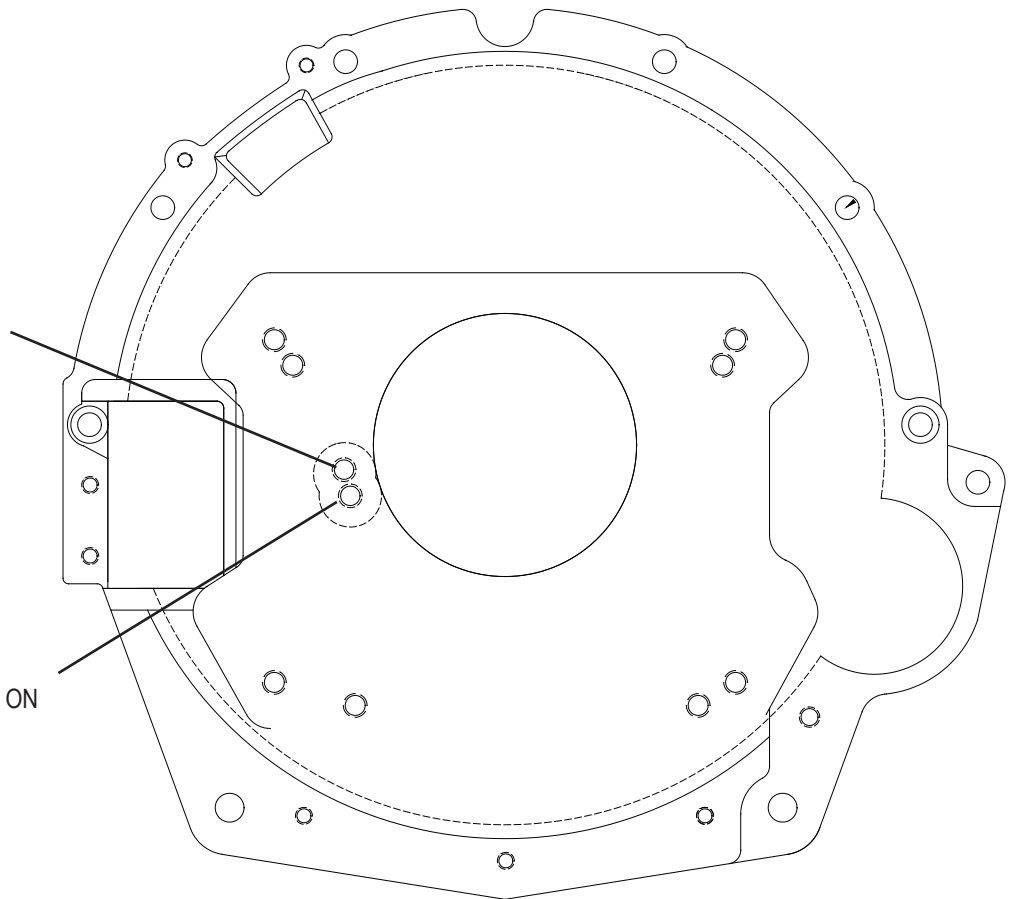

**CAUTION**

**CRITICAL SELECTION FOR BALL STUD LOCATION.**

**SPECIAL NOTE:** The components packaged in this kit have been assembled and machined for specific type of conversions. Modifications to any of the components will void any possible warranty or return privileges. If you do not fully understand modifications or changes that will be required to complete your conversion, we strongly recommend that you contact our sales department for more information. This instruction sheet is only to be used for the assembly of Advance Adapter components. We recommend that a service manual pertaining to your vehicle be obtained for specific torque values, wiring diagrams and other related equipment. These manuals are normally available at automotive dealerships and parts stores.