

ADVANCE ADAPTERS INC.

P.O. Box 247, 4320 Aerotech Center Way
Paso Robles, CA 93447

Telephone: (800) 350-2223 Fax: (805) 238-4201

P/N: 715630

PAGE 1 OF 2

Page Rev. Date: 07-18-02

SHIFTER LINKAGE ROD & LEVER KIT FOR EARLY BRONCO T&C TRANSMISSION

KIT CONSISTS OF:

No.	Qty	Part No.	Description
1.	3	303110	BUTTONS
2.	6	715650	NYLON BUSHINGS
3.	3	715651	CLIPS
4.	1	715653	LEVER
5.	1	715661	ROD
6.	1	715662	ROD
7.	1	715663	ROD
8.	1	715670	LEVER
9.	1	715678	LEVER
10.	3	303115	E-CLIP RETAINER V 

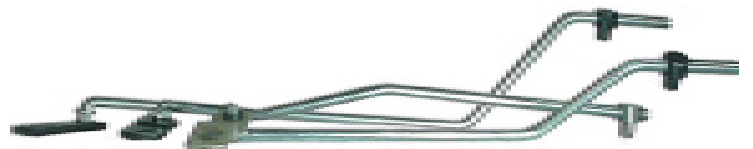
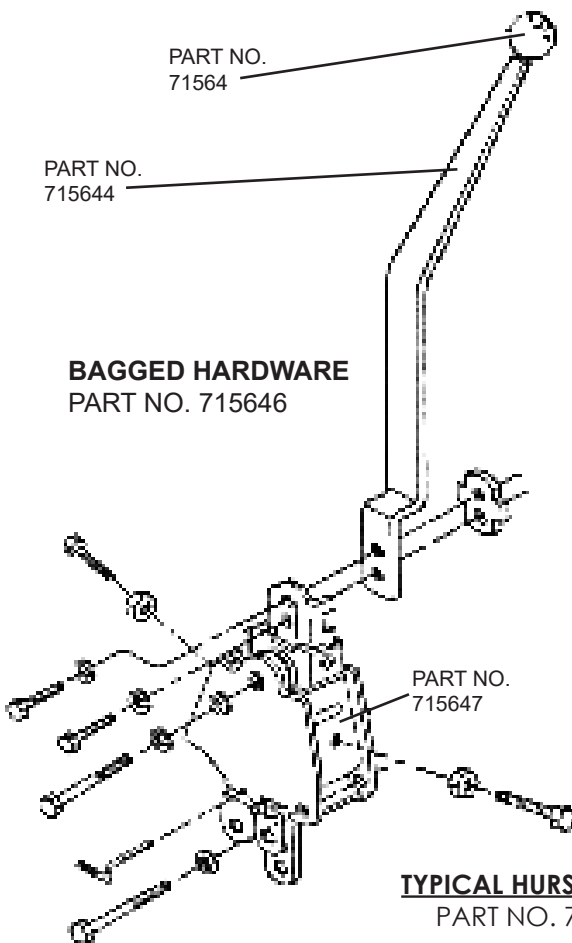
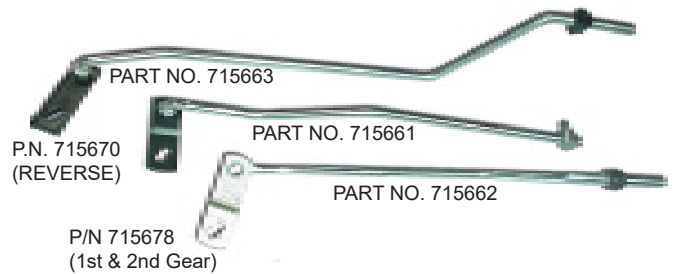

SPECIAL NOTE: The components packaged in this kit have been assembled and machined for specific type of conversions. Modifications to any of the components will void any possible warranty or return privileges. If you do not fully understand modifications or changes that will be required to complete your conversion, we strongly recommend that you contact our sales department for more information. This instruction sheet is only to be used for the assembly of Advance Adapter components. We recommend that a service manual pertaining to your vehicle be obtained for specific torque values, wiring diagrams and other related equipment. These manuals are normally available at automotive dealerships and parts stores.

ADVANCE ADAPTERS INC.

P.O. Box 247, 4320 Aerotech Center Way

Paso Robles, CA 93447

Telephone: (800) 350-2223 Fax: (805) 238-4201

P/N: 715630

PAGE 2 OF 2

Page Rev. Date: 07-18-02

SHIFTER LINKAGE ROD & LEVER KIT FOR EARLY BRONCO T&C TRANSMISSION

INSTALLATION INSTRUCTIONS:

1. Align levers with shifter frame and insert neutral ***alignment rod** through notches in frame and holes in levers. (***Use small bolt or pin to align**).
2. Rotate transmission arms backward and forward. The neutral position for each arm can be felt at the mid-position of full travel. Reverse arm must be moved to the end of its travel toward the front (disengage position).
3. Adjust position of button on each rod to permit easy slip-in fit of button into nylon bushings in proper lever. **Transmission arms must remain in neutral position while aligning is being performed.** Fasten buttons in levers with spring clips.
4. Remove neutral alignment rod. Test shifter. Stick should move freely from side to side at neutral (between 1-2 & 3-4 shifting paths). An increased pull towards the operator should engage the reverse lever.
5. Adjust shifter stop bolts. Back bolts out of shifter frame into 3rd gear and hold. Screw in 3rd gear stop bolt until contact is felt. Back out bolt one turn and tighten lock nut. Pull stick firmly back into 4th gear, screw in 4th gear stop bolt until contact is made, then back out stop bolt one turn and tighten lock nut.



SPECIAL NOTE: The components packaged in this kit have been assembled and machined for specific type of conversions. Modifications to any of the components will void any possible warranty or return privileges. If you do not fully understand modifications or changes that will be required to complete your conversion, we strongly recommend that you contact our sales department for more information. This instruction sheet is only to be used for the assembly of Advance Adapter components. We recommend that a service manual pertaining to your vehicle be obtained for specific torque values, wiring diagrams and other related equipment. These manuals are normally available at automotive dealerships and parts stores.