

## 6L80 TO 19 SPLINE TOYOTA LAND CRUISER

### ***KIT CONSISTS OF:***

<b><i>No.</i></b>	<b><i>Qty</i></b>	<b><i>Part No.</i></b>	<b><i>Description</i></b>
1.	1	51-0801	TOY L/C FJ60 PLATE LARGE HOLE
2.	1	51-7801	TOYOTA L/C- CIRCULAR 6 308 BEARING CASTING
3.	1	51-9600	ADAPTER- ATLAS TO 6L80/6L90
4.	1	52-0202	SHAFT- NV 32SP TO TLC 16SP
5.	1	716142	BUSHING/GEAR LOCATOR
6.	1	716310	308 SEALED BEARING
7.	1	716321	SPECIAL SNAP RING FOR 716310 BEARING
8.	1	716507	GASKET (gasket I.D. must be trimmed to fit bearing)
9.	1	716571	GASKET
10.	1	716758	DAUL LIP SEAL
11.	6	723711	STUD BOLT 3/8 -16 X 2 LG B7
12.	6	723701	NUT 3/8 -16 PLATED GRD 5
13.	8	724302	7/16" FLATWASHERS
14.	2	724309	7/16" H.H.C.S.
15.	1	724311	H.H.C.S. 7/16"-14 x 3-1/2" GR 5
16.	2	724312	7/16"-14 x 4" H.H.C.S.
17.	1	724322	7/16-14x 1" FHCS
18.	2	724328	7/16"-14 x 1-1/4" H.H.C.S.
19.	1	728703	METRIC SHAFT NUT 26-1.5
20.	2	720044	H.H.C.S. 10mm X 1.5TH X 20mm (rev B on casting ID crossmember threads)

If your transfer case was coupled to a manual transmission, Toyota used a single lip seal in the front of the transfer case. The recommend changing the seal with a double lip seal P/N 716758 that was used on the stock automatic applications. Toyota # 90316-48003

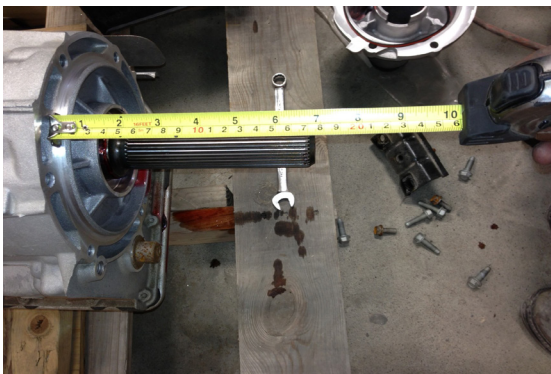

6.75" stickout on a 2WD transmission. the shaft will need to be cut or shortend to 4.00 cut off.

**SPECIAL NOTE:** \_\_\_\_\_ The components packaged in this kit have been assembled and machined for specific type of conversions. Modifications to any of the components will void any possible warranty or return privileges. If you do not fully understand modifications or changes that will be required to complete your conversion, we strongly recommend that you contact our sales department for more information. This instruction sheet is only to be used for the assembly of Advance Adapter components. We recommend that a service manual pertaining to your vehicle be obtained for specific torque values, wiring diagrams and other related equipment. These manuals are normally available at automotive dealerships and parts stores.



P.O. Box 247, 4320 Aerotech Center Way  
Paso Robles, CA 93447  
Telephone: (800) 350-2223 Fax: (805) 238-4201  
PAGE 2 OF 3 Page Rev. Date: 08-11-17  
P/N: 50-9612

## 6L80 TO 19 SPLINE TOYOTA LAND CRUISER

GM's new Hydra-Matic 6L80 transmission is the first of a new family of modular six-speed rear-drive transmissions. The transmissions feature two overdrive gears and a wide gear ratio spread to improve performance and fuel economy when compared with conventional four- and five-speed automatic transmissions. With two overdrive gears, engine rpm is reduced by approximately 9 percent at 60 mph - a reduction to about 1,500 rpm. GM estimates the wide ratio spread can help cut 0-60 mph times by as much as 7 percent and enhance fuel economy by up to 4 percent.

Engineering the all-new Hydra-Matic six-speed transmission with a modular architecture enabled engineers and designers to design a transmission that is easily adapted to a wide range of vehicles. Equally important, the new six-speed automatic's modular design means any of the four primary variants can be manufactured in the same assembly plant.

The modular design of the transmission permits several versions of the transmission to be tailored with minimal changes to the precise performance requirements of different vehicles. As many as 47 percent of all components are common for all four transmission variants. In fact, the new transmission design is so flexible that different variants theoretically could run sequentially down the same assembly line. The new six-speed automatic's manufacturing plan dovetails completely with GM's Global Manufacturing System strategy to implement a common manufacturing process and procedure at every worldwide GM assembly plant.

Technically sophisticated clutch-to-clutch operation reduces complexity and packaging. It also enhances the performance feel of the transmission, as shifts feel more immediate and precise. It is a simple, less complex design that enables the six-speed transmission to be packaged in a size not much larger than a four-speed automatic.

*Vehicles that were equipped originally with a manual transmission used a sleeve that locates the gear for the transmission rear bearing and provides a seal surface. These applications do not require the use of our spacer P/N 716142. You must retain this stock gear spacer on these applications. All other vehicles have the seal surface on the gear and will need to use the gear spacer included in this kit.*

*If your transfer case was coupled to a manual transmission, Toyota used a single lip seal in the front of the transfer case. We recommend changing the seal with a double lip seal that was used on the stock automatic applications.  
Toyota # 90316-48003*

**NOTES:** We do not offer a bracket for the transfer case shifter linkage. A custom bracket will have to be fabricated. The stock cross-member support is located under the stock transmission, a new crossmember or modification to the stock crossmember will be required.

The kit is designed around a stock 2WD 6L80E transmission output shaft. This output shaft must be shortened in order to be used.

**INSTALLATION INSTRUCTIONS:** When installing the new transfer case adapter, make sure that the coupler and the output shaft do not bottom out. We have found on occasion that the cut off location of the transmission output shaft may be slightly longer than what we have allowed for. When coupling the adapter housing and spud shaft to the back of the transmission, there should not be any interference. **DO NOT FORCE THE NEW TAILHOUSING ONTO THE TRANSMISSION.** If assistance is needed, please feel free to call the number listed above.

**SPECIAL NOTE:** The components packaged in this kit have been assembled and machined for specific type of conversions. Modifications to any of the components will void any possible warranty or return privileges. If you do not fully understand modifications or changes that will be required to complete your conversion, we strongly recommend that you contact our sales department for more information. This instruction sheet is only to be used for the assembly of Advance Adapter components. We recommend that a service manual pertaining to your vehicle be obtained for specific torque values, wiring diagrams and other related equipment. These manuals are normally available at automotive dealerships and parts stores.

## 6L80 TO 19 SPLINE TOYOTA LAND CRUISER

All installations will require the use of a transmission cooler. The cooler can be either installed in the radiator or a remote location is acceptable.

The back of the adapter must have a sealed bearing installed with the new snap ring indexing into the front of the transfer case. This bearing is trapped between the adapter housing and the transfer case. With the shaft and two adapters in position, you must then install P/N 716142 bushing for spacing the first transfer case gear. This bushing is very critical and will establish the actual position of the transfer case gears. Once the gears are installed, use the new transfer case lock nut to retain the gears in position.

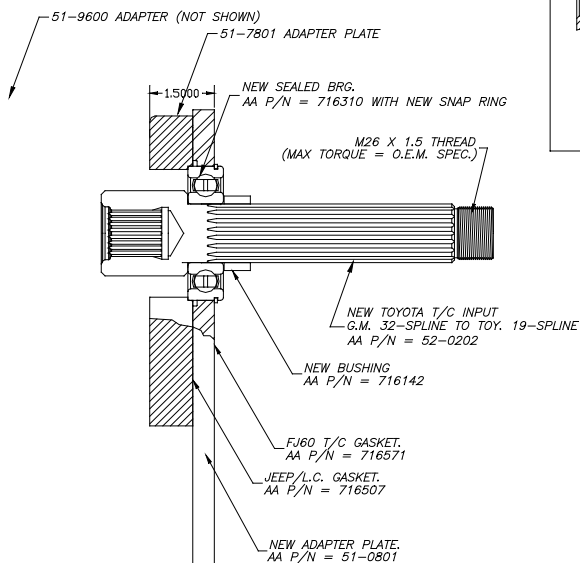
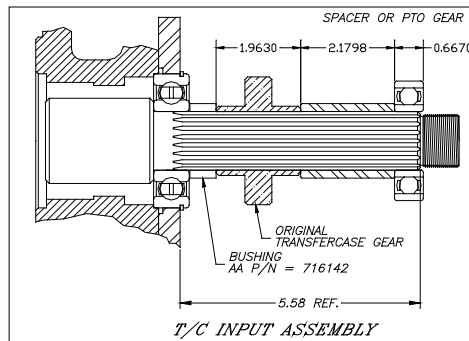
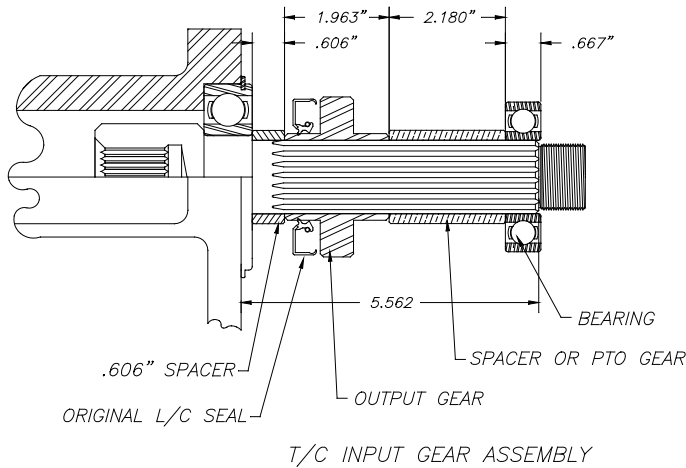

**SPECIAL NOTE: You may be required to change out the snap ring on the 308 bearing. The split-style transfer case used two different diameter snap ring grooves in the case. We have included both snap rings to fit both styles of transfer cases.**

**SPECIAL NOTE:** The components packaged in this kit have been assembled and machined for specific type of conversions. Modifications to any of the components will void any possible warranty or return privileges. If you do not fully understand modifications or changes that will be required to complete your conversion, we strongly recommend that you contact our sales department for more information. This instruction sheet is only to be used for the assembly of Advance Adapter components. We recommend that a service manual pertaining to your vehicle be obtained for specific torque values, wiring diagrams and other related equipment. These manuals are normally available at automotive dealerships and parts stores.