

ADVANCE ADAPTERS INC.

P.O. Box 247, 4320 Aerotech Center Way

Paso Robles, CA 93447

Telephone: (800) 350-2223 Fax: (805) 238-4201

P/N: 716022

PAGE 1 OF 1

Page Rev. Date: 03-09-16

TOYOTA LAND CRUISER TRANSFER CASE CROSSMEMBER SUPPORT ASSEMBLY

KIT CONSISTS OF:

No.	Qty	Part No.	Description
1.	1	713010-B	BOLT PACK KIT
2.	2	713046	FRAME MOUNTS
3.	1	713049	MAIN SUPPORT
4.	2	713049-PLT	3/16" THICK FRAME SCAB PLATES
5.	6	716065	10mm - 1.25 THD STUD BOLT
6.	1	716506	GASKETS
7.	2	716660	MOUNT-LARGE POLYURETHANE, 1.250" MALE INDEX
8.	2	716661	MOUNT-LARGE POLYURETHANE, 1.250" FEMALE INDEX
9.	2	716662	SLEEVE-BOLTSLEEVE
10.	6	720038	10mm LOCKWASHER
11.	6	720050	NUT

SPECIAL NOTE:

Install studs with long threaded end into transfer case. DO NOT OVER TORQUE.

As of 05-27-99, the rubber mount kit has been changed to a 1-1/4" index hole. Kits purchased before this date will require a 1-1/8" index hole, P/N 713008-NS.

INSTALLATION INSTRUCTIONS:

This unit is designed to replace the factory bellhousing mounts when changing engines and/or transmissions. Every support is cut from a 3/8" steel plate, and then fixture fitted and M.I.G. welded. All of this is done in every effort to maintain the highest possible quality product. We manufacture two variations to the Toyota crossmembers. The difference between the two is the frame width variation-to-transfer case adapters. The **716022** kit is used on all V8 conversions using the original 3 or 4 speed transmission. Kit **716022-TSW** is for exclusive use with the FJ55.

In all cases, the Land Cruiser frame will have to be scabbed over so that the frame brackets can be properly mounted. The frame brackets may then be bolted or welded into place. Driveshaft angles will also be determined by the positioning of the frame bracket. For best results, the transfer case and differential yokes should be parallel.

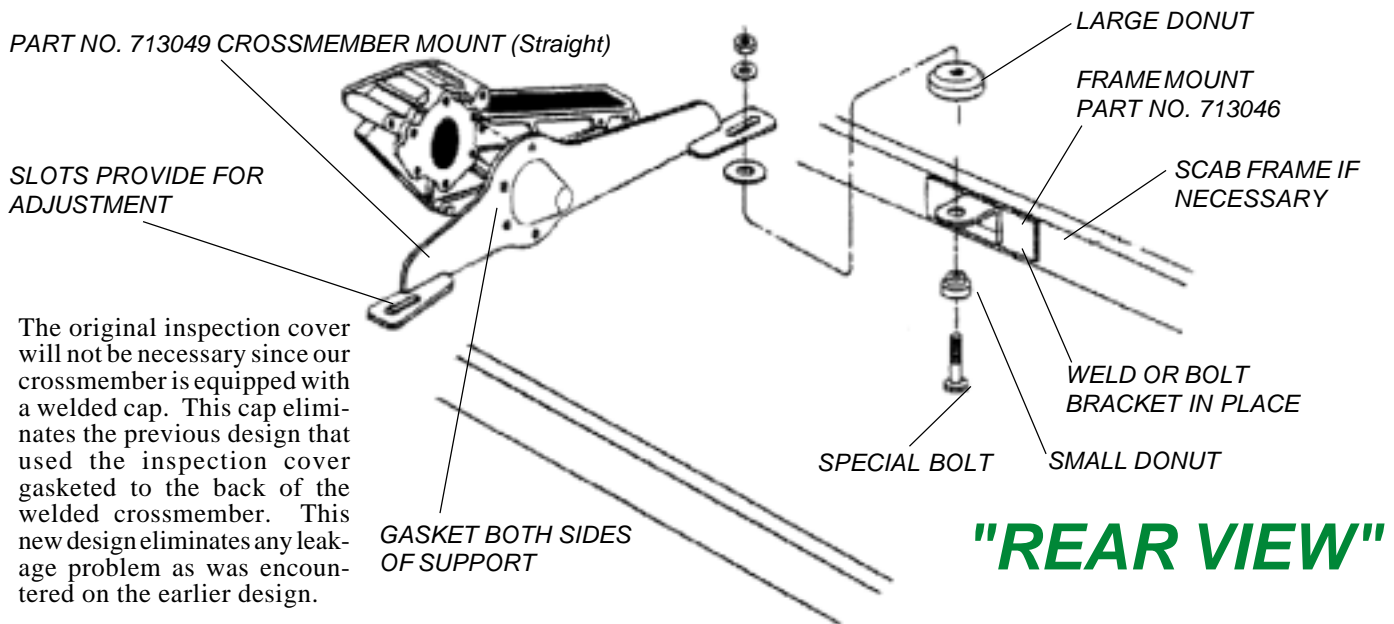

The original inspection cover will not be necessary since our crossmember is equipped with a welded cap. This cap eliminates the previous design that used the inspection cover gasketed to the back of the welded crossmember. This new design eliminates any leakage problem as was encountered on the earlier design.

SPECIAL NOTE: The components packaged in this kit have been assembled and machined for specific type of conversions. Modifications to any of the components will void any possible warranty or return privileges. If you do not fully understand modifications or changes that will be required to complete your conversion, we strongly recommend that you contact our sales department for more information. This instruction sheet is only to be used for the assembly of Advance Adapter components. We recommend that a service manual pertaining to your vehicle be obtained for specific torque values, wiring diagrams and other related equipment. These manuals are normally available at automotive dealerships and parts stores.