

# ADVANCE ADAPTERS, INC.

P.O. Box 247, 4320 Aerotech Center Way

Paso Robles, CA 93447

Telephone: (800) 350-2223 Fax: (805) 238-4201

# P/N: 50-0431A

New Kit: (02/03)

PAGE: 1 OF 5

Page Rev. Date: 05-29-15

## GM 4L60E TO NP231 TRANSFER CASES (21SPL) upgrading to 95 & NEWER 23SPL.

### KIT CONSISTS OF:

No.	Qty	Part No.	Description
1.	1	51-0405	4L60E / UNIVERSAL ADAPTER
2.	1	51-6800	ADAPTER CASTING (Ref: 711168)
3.	1	52-9101	700R-4 SHAFT
4.	1	300619	RELUCTOR SENSOR
5.	1	716095	23 SPLINE 95 & UP TC INPUT
6.	1	716760	NP231 INPUT SEAL
7.	1	716079	22mm PLUG
8.	1	716072	RELUCTOR RING CLAMP RING (One piece reluctor, bolt torque 10 ft-lbs.)
9.	1	716082	700R PLASTIC WASHER
10.	1	716511	O-RING (51-6800 CASTING)
11.	1	716517	GASKET, NP208 T/C
12.	1	716729	SEAL (NAT. #456057) (ADAPTER)
13.	6	720015	10mm FLAT WASHER (USE ON 10mm BOLTS)
14.	6	720037	10mm x 1.5mm x 35mm H.H.C.S. (INTO 4L60 CASE)
15.	6	720038	10mm LOCK WASHER (USE ON 10mm BOLTS)
16.	4	720046	S.H.C.S. 10mm-1.5 X 40mm LG. (51-6800 TO THE 51-0405)
17.	6	723701	NUT 3/8"-16 PLATED (USE ON STUDS)
18.	6	723704	3/8" LOCKWASHERS (USE ON STUDS)
19.	6	723711	STUD BOLT 3/8"-16 x 2" LG (TRANSFER CASE STUDS)
20.	2	723730	S.H.C.S. 3/8"-16 x 1-1/4" LG. (STUD REPLACEMENTS)

### OPTIONAL ITEMS:

Qty	Part No.	Description
1	716008	Crossmember mount



In 1996, GM produced a newer version of its electronically controlled 4L60E. This 4L60E transmission is 21-1/2" long, and has a removable bellhousing. It has a hex bolt pattern on the output side of the transmission, similar to a TH400.



The kit which you have purchased was designed not only to adapt the 4L60E to the NP231 case, but also to maintain the pulse generator to run the computer. We have included a 700R4 shaft in this kit to be installed in the transmission. Once installed in the transmission, you may begin to assembly the pulse system on the transmission. First is the reluctor ring. This clamp-on reluctor ring fits over the stock governor gear on the supplied output shaft. It creates 40 pulses for each revolution of the output shaft for the drivetrain control module. We have provided two reluctor sensor locations to choose from in the adapter. The hole not being used will need to be plugged with the brass plug provided.

**SPECIAL NOTE:** The components packaged in this kit have been assembled and machined for specific types of conversions. Modifications to any of the components will void any possible warranty or return privileges. If you do not fully understand the modifications or changes that will be required to complete your conversion, we strongly recommend that you contact our sales department for more information. This Instruction Sheet is only to be used for the assembly of Advance Adapter components. We recommend that a service manual pertaining to your vehicle be obtained for specific torque vales, wiring diagrams and other related equipment. These manuals are normally available at automotive dealerships and parts stores.

# ADVANCE ADAPTERS, INC.

P.O. Box 247, 4320 Aerotech Center Way

Paso Robles, CA 93447

Telephone: (800) 350-2223 Fax: (805) 238-4201

P/N: 50-0431A

New Kit: (02/03)

PAGE: 2 OF 5

Page Rev. Date: 05-01-13

## GM 4L60E TO NP231 TRANSFER CASES (21SPL) upgrading to 95 & NEWER 23SPL.

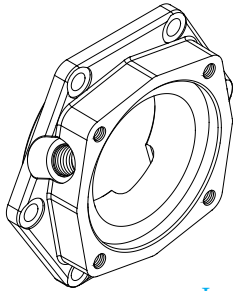

### Pulse Generator Installation:

Slide the reluctor ring over the 4L60E shaft installed in the transmission. Push the ring completely onto the shaft until it bottoms out. Lightly snug the set screws for a "dry run". Trial fit the 51-0405 adapter plate onto the back of the 4L60E transmission using two of the supplied bolts. With the adapter bolted on the back of the transmission, install the 300619 reluctor sensor into the adapter casting. The 300619 sensor should line up over the teeth of the reluctor clamp. (If the clamp-on ring is not completely bottomed out, this may cause a miss-alignment with the sensor). When you have confirmed the correct location of the shaft, remove the adapter housing. Make sure you do not disturb the position of the clamp on the shaft. With the clamp now exposed, tighten the set screws on the clamp.

Loctite is highly recommended on these set screws.

You should now be ready for final installation of the 51-0405 casting. **RTV Blue Silicone** should be used to seal adapter 51-0405 to your 4L60E transmission. Use all of the supplied bolts for the casting and torque according to factory specs. Next, screw the 300619 sensor completely into the 51-0405 casting. Be careful not to force this sensor once it has contacted the shaft. Slowly back the sensor out of the hole and with a feeler gauge.

Check the gap between the sensor and the reluctor ring. This gap should be around 0.010" to 0.012". Once 0.010" to 0.012" clearance is obtained, Loctite the sensor into position.

You are now ready to bolt your conversion adapter to the 51-0405 kit. **NOTE:**

**On a few applications, customers have not positioned the clamp in the correct position which has caused interference with the input shaft in the transfer case. If you try bolting the conversion adapter up to the 51-0405 and find interference, the spud shaft may be hitting the clamp on the reluctor.**

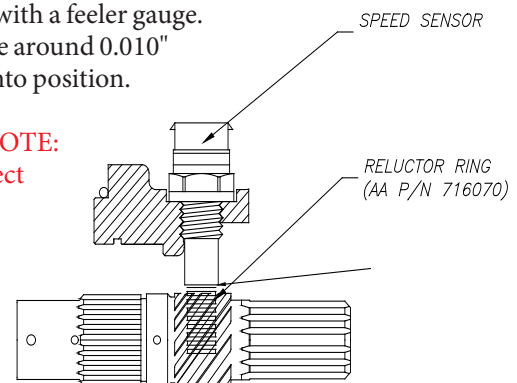

### ASSEMBLY PROCEDURES:

1. Trial fit the 51-6800 adapter on the already installed 51-0405 casting. Check to see that the castings seat flush against each other. Use two of the supplied bolts to temporarily hold these together.
2. Trial fit the transfer case to the adapter and transmission. Check for spline engagement and shaft depth into the input coupler of the transfer case. If the transfer case does not mate flush against the casting, **DO NOT DRAW IT TOGETHER WITH THE FASTENERS. SEVERE DAMAGE WILL OCCUR.** This is **not** normally found when replacing an AX15 manual transmission. If interference is detected, the output shaft must be shortened to a flush stickout with reference to the casting. **On Automatic Torqueflite 999 applications where the factory output shaft does not protrude beyond the stock adapter, the will need shaft modifications.** Cutting the shaft will require a cut off disc to cut the outer edges, and a hacksaw to cut through the center. If you are unsure about cutting, please call us toll free at 1-800 350-2223. If you do not have the ability to cut your shaft, a 1" spacer is available (Part No. 51-0404).
4. Remove the 51-6800 adapter, then press the seal into the casting with the open side toward the transmission.
5. For final installation, install the rubber o-ring on the transmission side of the adapter. A thin bead of silicone should be applied as a sealant.
6. The four 3/8"-16 x 1-3/4" Socket Head Cap Screws are then used to secure the casting to the transmission.

**SPECIAL NOTE:** The components packaged in this kit have been assembled and machined for specific types of conversions. Modifications to any of the components will void any possible warranty or return privileges. If you do not fully understand the modifications or changes that will be required to complete your conversion, we strongly recommend that you contact our sales department for more information. This Instruction Sheet is only to be used for the assembly of Advance Adapter components. We recommend that a service manual pertaining to your vehicle be obtained for specific torque vales, wiring diagrams and other related equipment. These manuals are normally available at automotive dealerships and parts stores.

# ADVANCE ADAPTERS, INC.

P.O. Box 247, 4320 Aerotech Center Way

Paso Robles, CA 93447

Telephone: (800) 350-2223 Fax: (805) 238-4201

P/N: 50-0431A

New Kit: (02/03)

PAGE: 3 OF 4

Page Rev. Date: 02-11-13

## GM 4L60E TO NP231 TRANSFER CASES (21SPL) upgrading to 95 & NEWER 23SPL.

- Two rotations are provided on the casting. Choose the rotation that best suits your application.
- Studs and nuts are provided for securing the transfer case.
- Two of the positions on the rotation will require removal of two studs from the transfer case and substitution by the two 3/8"-16 x 1-1/4" Socket Head Cap Screws. This is due to lack of wrench clearance around the casting.
- Use silicone sealant on both sides of the transfer case gasket. Use Loctite on all bolts.

### Notes:

Again, when installing the new transfer case adapter, make sure that the transfer case input sleeve and the output shaft do not bottom out. We have found on occasion that a transmission output shaft may be slightly longer than we have allowed for; and when coupling into the transfer case, we find a small amount of interference. The adapter housing and shaft must be assembled to the back of the transmission without interference. **DO NOT FORCE THE NEW TAILHOUSING ONTO THE TRANSMISSION.** If assistance is needed, please feel free to call us on our toll free number, 1-800 350-2223.

This adapter can be used on either Jeep Wranglers 1987 & newer or Jeep Cherokees 1984 & newer. The only difference is the transfer case shifter linkage. The adapter combination is 2.875" thick and will provide an overall transmission assembly length of 24-7/8". On conversions using the 4L60E, you can anticipate driveshaft modifications. The adapter crossmember support is designed around the replacement of a manual transmission. If you are replacing an automatic transmission, you will find that the crossmember support will hang too far down when it is bolted to the bottom of our new adapter housing. We suggest that you purchase a crossmember support from the manual transmission application to simplify this problem.

The transfer case shift linkage is mounted in two different designs. Jeep Wranglers 1987-96 will require shifter bracket No. 715523, while Cherokee conversions will require shifter bracket No. 715524. Some applications will require the purchase of a stock Jeep bracket, #53004280. This is the most universal bracket for YJ Wranglers. TJ conversions will need to space the body bracket to use the stock linkage.

*THE 700R HAD A DESIGN CHANGE ON THE OUTPUT SHAFT. THE OIL HOLE HAS BEEN RELOCATED TO THE CHAMFER ON THE SHAFT. THE INPUT HOUSING LUBE SEAL (SOFT AND RED IN COLOR) FOR THE LATER DESIGN SHAFTS MUST BE CHANGED TO THE HARD PLASTIC SEAL PROVIDED IN THE KIT. MOST OF THE OUTPUT SHAFTS WE USE ARE AN EARLIER DESIGN SHAFT WHICH WILL ONLY WORK WITH THE HARD PLASTIC WASHER SUPPLIED IN THIS KIT.*

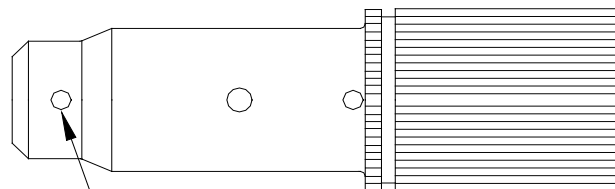

*THE 700R PREVIOUS DESIGN LUBE HOLE LOCATION  
EARLY DESIGN SHAFT (REQUIRES HARD PLASTIC WASHER)*

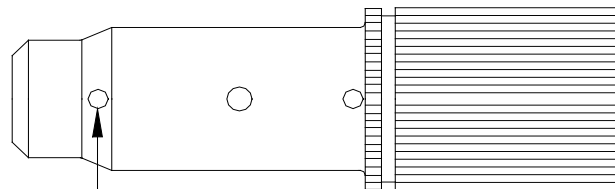

*THE 700R REVISED LUBE HOLE LOCATION  
LATE MODEL SHAFT (CAN USE EITHER SOFT OR HARD PLASTIC WASHER)*

**SPECIAL NOTE:** The components packaged in this kit have been assembled and machined for specific types of conversions. Modifications to any of the components will void any possible warranty or return privileges. If you do not fully understand the modifications or changes that will be required to complete your conversion, we strongly recommend that you contact our sales department for more information. This Instruction Sheet is only to be used for the assembly of Advance Adapter components. We recommend that a service manual pertaining to your vehicle be obtained for specific torque values, wiring diagrams and other related equipment. These manuals are normally available at automotive dealerships and parts stores.

# ADVANCE ADAPTERS, INC.

P.O. Box 247, 4320 Aerotech Center Way

Paso Robles, CA 93447

Telephone: (800) 350-2223 Fax: (805) 238-4201

P/N: 50-0431A

New Kit: (02/03)

PAGE: 4 OF 5

Page Rev. Date: 2-11-13

## GM 4L60E TO NP231 TRANSFER CASES (21SPL) upgrading to 95 & NEWER 23SPL.

### INSTRUCTIONS for NP 231 input gear:

This new input gear will only fit the NP231 transfer cases. The installation of the gear will require the complete disassembly of your NP231 transfer case. Since the transfer case has to be completely disassembled, this is also a good time to install a short output shaft kit (fixed yoke kit) if you already have not done so.

If you've never disassembled a New Process transfer case, here are a couple of points to keep in mind that will make the installation much easier:

1. Keep all bolts, nuts, washers, etc. separated into groups as you remove them. Make sure you keep them in a labeled container that indicates what part of the transfer case they came from.
2. Keep all small parts in separate containers and label as to location and origin.
3. Make sure you have plenty of time and have a clean, spacious area to perform the installation.

Remove the front yoke nut with a 1-1/8" socket using an impact wrench. Remove the rear case bolts. A 10mm 12 pt. socket is needed for the spline head bolt and a 15mm socket for the remaining bolts. **NOTE:** The two black oxide finished bolts are located at the case dowel positions and require a washer under them. Start to remove the rear case from the front case by inserting pry bars at the cast-in locations **ONLY!** Pry apart evenly to break the sealer bead along the case mating surfaces. The front output shaft and chain should be retained with the rear portion of the case.



On the front side of the transfer case, you'll need to remove the 4 bolts that retain the aluminum bearing retainer. Once this removed, you'll find a snap ring that retains the input gear to the cases' input bearing. This snap ring must be removed so that the input gear can be removed from the inside.

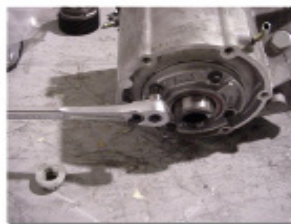

On the inside of the transfer case, you'll now be able to remove the planetary assembly. Set the assembly on a work bench and locate the snap ring that retains the input gear into the planetary housing. Remove the snap ring and lift the input gear out of the planetary housing.



**SPECIAL NOTE:** The components packaged in this kit have been assembled and machined for specific types of conversions. Modifications to any of the components will void any possible warranty or return privileges. If you do not fully understand the modifications or changes that will be required to complete your conversion, we strongly recommend that you contact our sales department for more information. This Instruction Sheet is only to be used for the assembly of Advance Adapter components. We recommend that a service manual pertaining to your vehicle be obtained for specific torque values, wiring diagrams and other related equipment. These manuals are normally available at automotive dealerships and parts stores.

# ADVANCE ADAPTERS, INC.

P.O. Box 247, 4320 Aerotech Center Way

Paso Robles, CA 93447

Telephone: (800) 350-2223 Fax: (805) 238-4201

P/N: 50-0431A

New Kit: (02/03)

PAGE: 5 OF 5

Page Rev. Date: 02-11-13

## GM 4L60E TO NP231 TRANSFER CASES (21SPL) upgrading to 95 & NEWER 23SPL.

Once the input gear is removed, you'll find a thrust washer that must be reinstalled onto the new 23 spline input. When comparing the two input gears, they should look the same except for the internal splines. If you find a difference between the two. The NP231 transfer case used two styles of front input bearings. The early transfer case used a wide bearing and the later model used a narrow bearing. This new input gear is designed for only the early style case. New Process changed the bearing and gear pitch design in 1995. The center photo below show a later model input compared to a early.

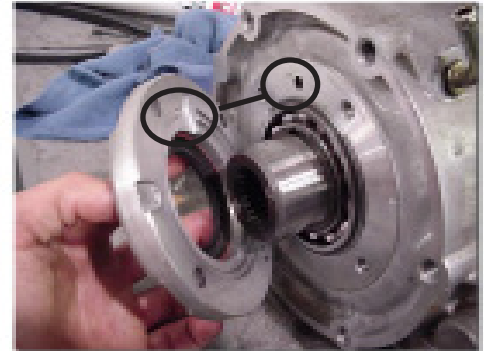

Once you have verified that you have the same style input gear, install the gear into the planetary, install the snap ring. Re-install the planetary assembly into the case and secure the input to the bearing with the front snap ring. **Note:** The only part you should have left out of the case is the old input gear. During reassembly, make sure the oil return hole matches the front retainer hole.

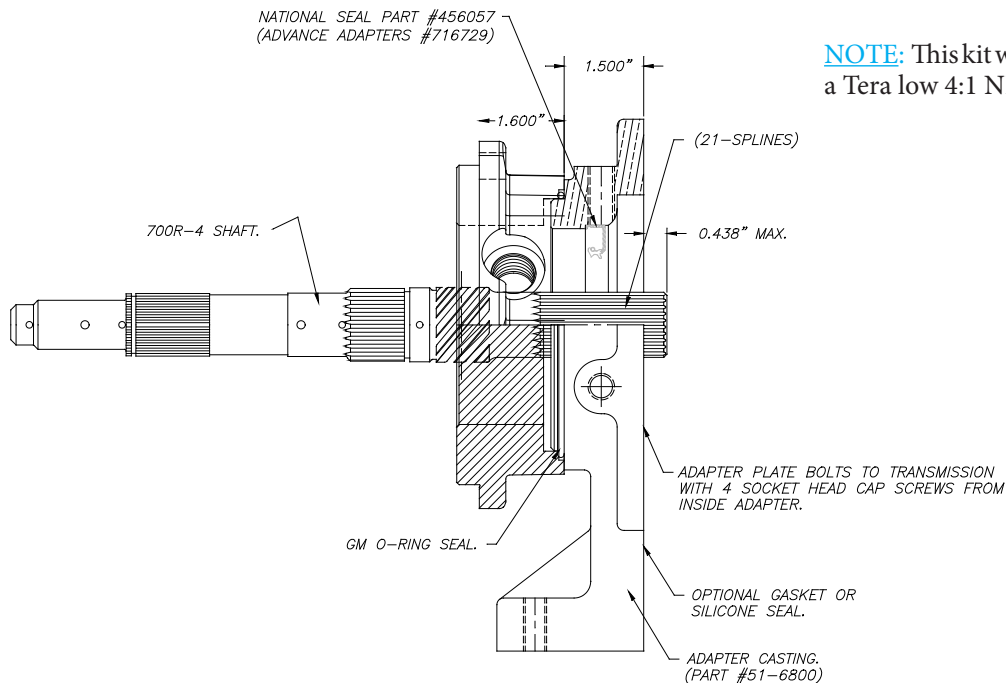

**NOTE:** This kit will not work with a Tera low 4:1 NP231 kit.

### NOTES:

1. Be sure that the adapter shaft and T/C input gear do not bottom out prior to the adapter meeting flush with the transmission. Some models may require the output shaft to be shortened.
2. The adapter has provisions for a new seal (NAT #456057). The outside diameter is 3.75" and the inside diameter is 1.937". The seal must be installed with the open side towards the transmission.

**SPECIAL NOTE:** The components packaged in this kit have been assembled and machined for specific types of conversions. Modifications to any of the components will void any possible warranty or return privileges. If you do not fully understand the modifications or changes that will be required to complete your conversion, we strongly recommend that you contact our sales department for more information. This Instruction Sheet is only to be used for the assembly of Advance Adapter components. We recommend that a service manual pertaining to your vehicle be obtained for specific torque vales, wiring diagrams and other related equipment. These manuals are normally available at automotive dealerships and parts stores.