

ADVANCE ADAPTERS INC.

P.O. Box 247, 4320 Aerotech Center Way

Paso Robles, CA 93447

Telephone: (800) 350-2223 Fax: (805) 238-4201

P/N: 50-1501

PAGE 1 OF 3

Page Rev. Date: 02-19-07

4L80E TO TOYOTA LAND CRUISER 10 SPLINE FJ40

KIT CONSISTS OF:

No.	Qty	Part No.	Description
1.	1	51-0702	ADAPTER CASTING (Ref: 711107 - MODIFIED)
2.	1	52-0200	SPUD SHAFT 10 SPLINE X 32 SPLINE
3.	1	716301	SEALED BEARING
4.	1	716507	GASKET
5.	1	716510	GASKET
6.	6	720011	10mm x 1.5 NUT
7.	6	720061	10mm x 1.5 50mm LONG STUD BOLT
8.	5	724302	7/16" FLAT WASHERS
9.	3	724345	7/16" -14 x 5" H.H.B.
10.	2	724349	7/16" -14 x 1-1/2" H.H.B.
11.	1	728701	NYLON NUT
12.	1	728702	7/8" FLAT WASHER
13.	1	TLC001	LAND CRUISER INSTRUCTION MANUAL

NOTES:

We do not offer a bracket for the transfer case shifter linkage. A custom bracket will have to be fabricated.

The kit is designed around a stock 4WD 4L80E transmission output shaft. This output shaft must be shortened in order to be used. The cut off location of this shaft must be 1.600' from the back side (output side) of this 4L80E transmission.

The 4L80E transmission is normally equipped with an internal reluctor ring on both the transmission input shaft and output shaft. The computer takes both of these readings for the proper shifting and operation of this transmission. We have always ignored the reluctor ring requirement for this transmission since it is internally regulated. We have now learned that the rear reluctor ring is not always installed into the transmission. The basic rule of thumb is 4WD transmissions up to 1996 should have a rear reluctor ring in the main transmission case. All 2WD transmissions should have the rear reluctor in the main transmission case. The 1997 & newer 4WD 4L80E transmissions have a sensor provision; however, the reluctor ring in the transmission is left out. To have this transmission operate correctly the rear reluctor ring should be installed into the transmission case.

Note: The information on years and models of the 4L80E transmission mentioned in the above section was obtained from various sources. You should always verify what your transmission is equipped with before beginning a conversion, especially with the 4L80E transmission.

SPECIAL NOTE: The components packaged in this kit have been assembled and machined for specific type of conversions. Modifications to any of the components will void any possible warranty or return privileges. If you do not fully understand modifications or changes that will be required to complete your conversion, we strongly recommend that you contact our sales department for more information. This instruction sheet is only to be used for the assembly of Advance Adapter components. We recommend that a service manual pertaining to your vehicle be obtained for specific torque values, wiring diagrams and other related equipment. These manuals are normally available at automotive dealerships and parts stores.

ADVANCE ADAPTERS INC.

P.O. Box 247, 4320 Aerotech Center Way

Paso Robles, CA 93447

Telephone: (800) 350-2223 Fax: (805) 238-4201

P/N: 50-1501

PAGE 2 OF 3

Page Rev. Date: 03-18-05

4L80E TO TOYOTA LAND CRUISER 10 SPLINE FJ40

INSTALLATION INSTRUCTIONS: When installing the new transfer case adapter, make sure that the coupler and the output shaft do not bottom out. We have found on occasion that the cut off location of the transmission output shaft may be slightly longer than what we have allowed for. When coupling the adapter housing and spud shaft to the back of the transmission, there should not be any interference. **DO NOT FORCE THE NEW TAILHOUSING ONTO THE TRANSMISSION.** If assistance is needed, please feel free to call the number listed above. When assembling the adapter housing to the transmission case, we have provided you with a new gasket to prevent fluid leakage. This gasket is a stock GM item that is used on all 4L80E installations.

On most installations, a slight pan modification will be required for clearance of the front universal yoke. This modification will be necessary on both the metal pan and the aluminum transmission case. The area where the pan and case come together (that has the bolt holding the two) will need to be ground down almost even with the body of the bolt. The bolt may need to be replaced with a socket head cap screw. These modifications can be done with the pan still attached to the transmission case. The metal pan will need the corner recessed approximately 1/2". These modifications should be made prior to assembly into the vehicle. In order to allow for additional front driveline clearance, we recommend that the engine and transfer case be offset to the driver's side on vehicles having front driveshafts located on the passenger's side. On Jeep and Toyota Land Cruiser conversions, this can be approximately 1" offset of centerline.

All installations will require the use of a transmission cooler. The cooler can be either installed in the radiator or a remote location is acceptable. The transmission shift control should be a cable linkage.

The back of the adapter must have a sealed bearing installed with the snap ring. The bearing will then index into the transfer case. This bearing is trapped between the adapter housing and the transfer case.

The stock transfer case shift linkage must have a new mounting bracket fabricated. We do not offer any brackets for this stock linkage.

The 4L80E transmission is normally equipped with an internal reluctor ring on both the transmission input shaft and output shaft. The computer takes both of these reading for the proper shifting and operation of this transmission. We have always ignored the reluctor ring requirement for this transmission since it is internally regulated. We have now learned that the rear reluctor ring is not always installed into the transmission. The basic rule of thumb is 4WD transmissions up to 1996 should have a rear reluctor ring in the main transmission case. All 2WD transmissions should have the rear reluctor in the main transmission case. The 1997 & newer 4WD 4L80E transmissions had a sensor provision; however, the reluctor ring in the transmission was left out. This adapter does not offer any type of reluctor pick up on the adapter, so you should make sure you transmission has the reluctor installed in the transmission case. **Note:** The information on years and models of the 4L80E transmission mentioned in the above section was obtained from various sources. You should always verify what your transmission is equipped with before beginning a conversion with the 4L80E transmission.

SPECIAL NOTE: The components packaged in this kit have been assembled and machined for specific type of conversions. Modifications to any of the components will void any possible warranty or return privileges. If you do not fully understand modifications or changes that will be required to complete your conversion, we strongly recommend that you contact our sales department for more information. This instruction sheet is only to be used for the assembly of Advance Adapter components. We recommend that a service manual pertaining to your vehicle be obtained for specific torque values, wiring diagrams and other related equipment. These manuals are normally available at automotive dealerships and parts stores.

ADVANCE ADAPTERS INC.

P.O. Box 247, 4320 Aerotech Center Way
Paso Robles, CA 93447

Telephone: (800) 350-2223 Fax: (805) 238-4201

P/N: 50-1501

PAGE 3 OF 3

Page Rev. Date: 03-18-05

4L80E TO TOYOTA LAND CRUISER 10 SPLINE FJ40

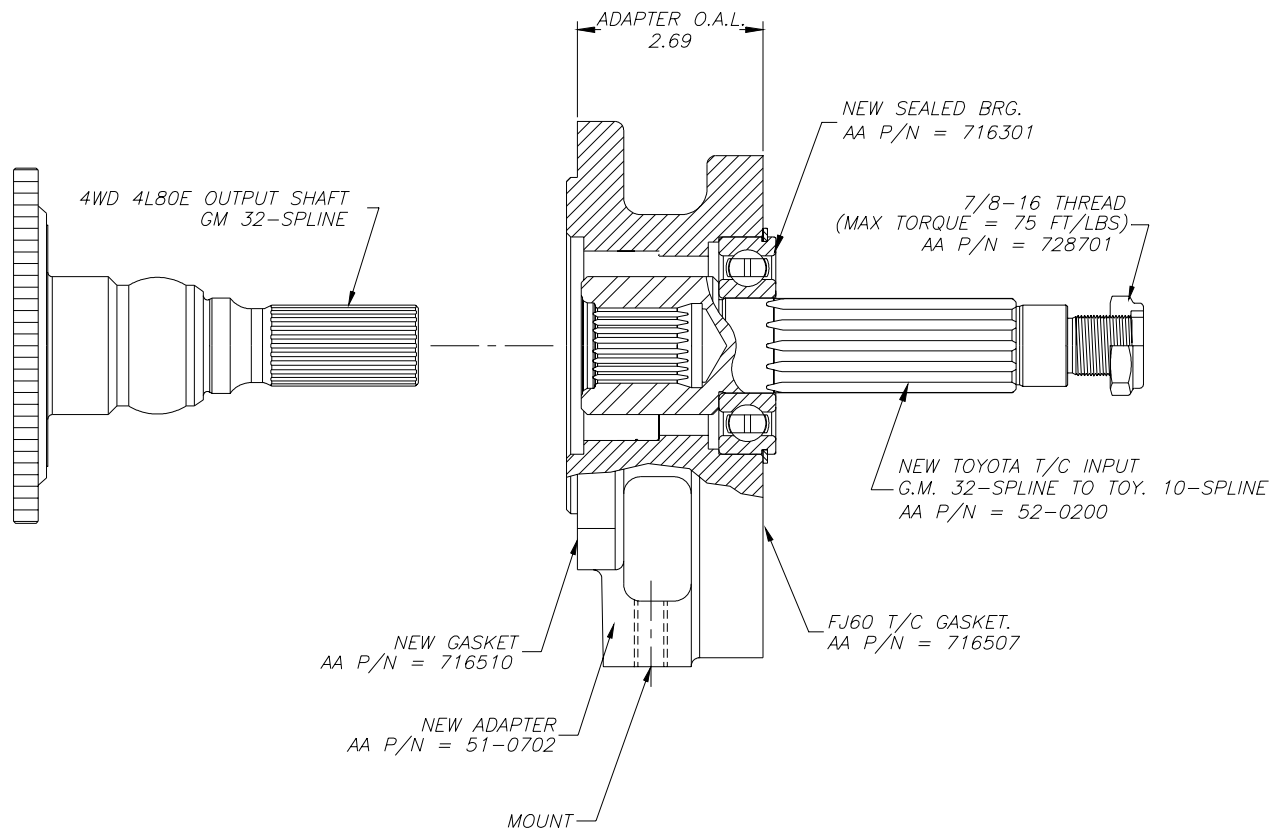

SPECIAL NOTE: The components packaged in this kit have been assembled and machined for specific type of conversions. Modifications to any of the components will void any possible warranty or return privileges. If you do not fully understand modifications or changes that will be required to complete your conversion, we strongly recommend that you contact our sales department for more information. This instruction sheet is only to be used for the assembly of Advance Adapter components. We recommend that a service manual pertaining to your vehicle be obtained for specific torque values, wiring diagrams and other related equipment. These manuals are normally available at automotive dealerships and parts stores.