



4320 Aerotech Center Way
Paso Robles, CA 93447
Telephone: (800) 350-2223 Fax: (805) 238-4201
PAGE 1 OF 2 Page Rev. Date: 10-06-21
P/N: 920013

SATURN OVERDRIVE SHIFT LINKAGE T14 SATURN SHIFT KIT

KIT CONSISTS OF:

| <u>No.</u> | <u>Qty.</u> | <u>Part No.</u> | <u>Description</u> |
|------------|-------------|-----------------|---|
| 1 | 1 | 303121 | NUT-1/2-13 HX JAM BLACK ZINC |
| 2 | 1 | 42R509 | 1/2 X 3/8 IGUS BUSHING |
| 3 | 1 | 716140 | BRAKE YOKE AND PIN 3/8-24 |
| 4 | 5 | 722546 | SCREW-TEK HEX SELF DRILLING W/NEO #10- 16 X 1 |
| 5 | 2 | 723105 | H.H.C.S. 5/16 -18 X 1 LG |
| 6 | 1 | 920016 | STICKER- SATURN/RANGER SHIFTERS |
| 7 | 1 | 920017 | WASHER-SATURN SHIFTER LINKAGE |
| 8 | 1 | 920018 | SHIFTER SNAP RING |
| 9 | 1 | 920019 | LEVER- SATURN SHIFTER |
| 10 | 1 | 920021 | SHIFTER BOOT T90 DUAL HANDLE |
| 11 | 1 | 920022 | BOOT RING- SATURN T90 DUAL |
| 12 | 1 | 920023 | SHIFTER WAVE WASHER |
| 13 | 1 | 920032 | SHIFT ROD- SATURN T90 SINGLE LEVER |
| 14 | 1 | 920033 | BRACKET- SATURN T14 LEVER |
| 15 | 1 | 302083 | SHIFTER KNOB |

The shifter bracket fits directly over the top cover plate of the 3 speed transmission and the pivot extends outward towards the passenger side of the vehicle. To access the assembly of the T14 transmission, the sheet metal tunnel cover will need to be removed. When mounting the shifter bracket, you will need to use the steel spacer washers between the top cover and the shifter bracket. New bolts have been supplied for the bracket assembly to the transmission. The linkage rod must be installed into shift rail on the back side of the overdrive. With the extension rod in position and the shifter bracket in position, you can now install the handle assembly. The handle will slip over the shifter bracket pin as illustrated. The clevis assembly (or brake yoke), will then slip onto the shifter handle. At this point, the adjustment between the shifter handle and the linkage rod can be determined. The handle should be positioned in a vertical position and the shifter rod in the overdrive should be positioned into the neutral location.

SPECIAL NOTE: The components packaged in this kit have been assembled and machined for specific type of conversions. Modifications to any of the components will void any possible warranty or return privileges. If you do not fully understand modifications or changes that will be required to complete your conversion, we strongly recommend that you contact our sales department for more information. This instruction sheet is only to be used for the assembly of Advance Adapter components. We recommend that a service manual pertaining to your vehicle be obtained for specific torque values, wiring diagrams and other related equipment. These manuals are normally available at automotive dealerships and parts stores.

SATURN OVERDRIVE SHIFT LINKAGE T14 SATURN SHIFT KIT

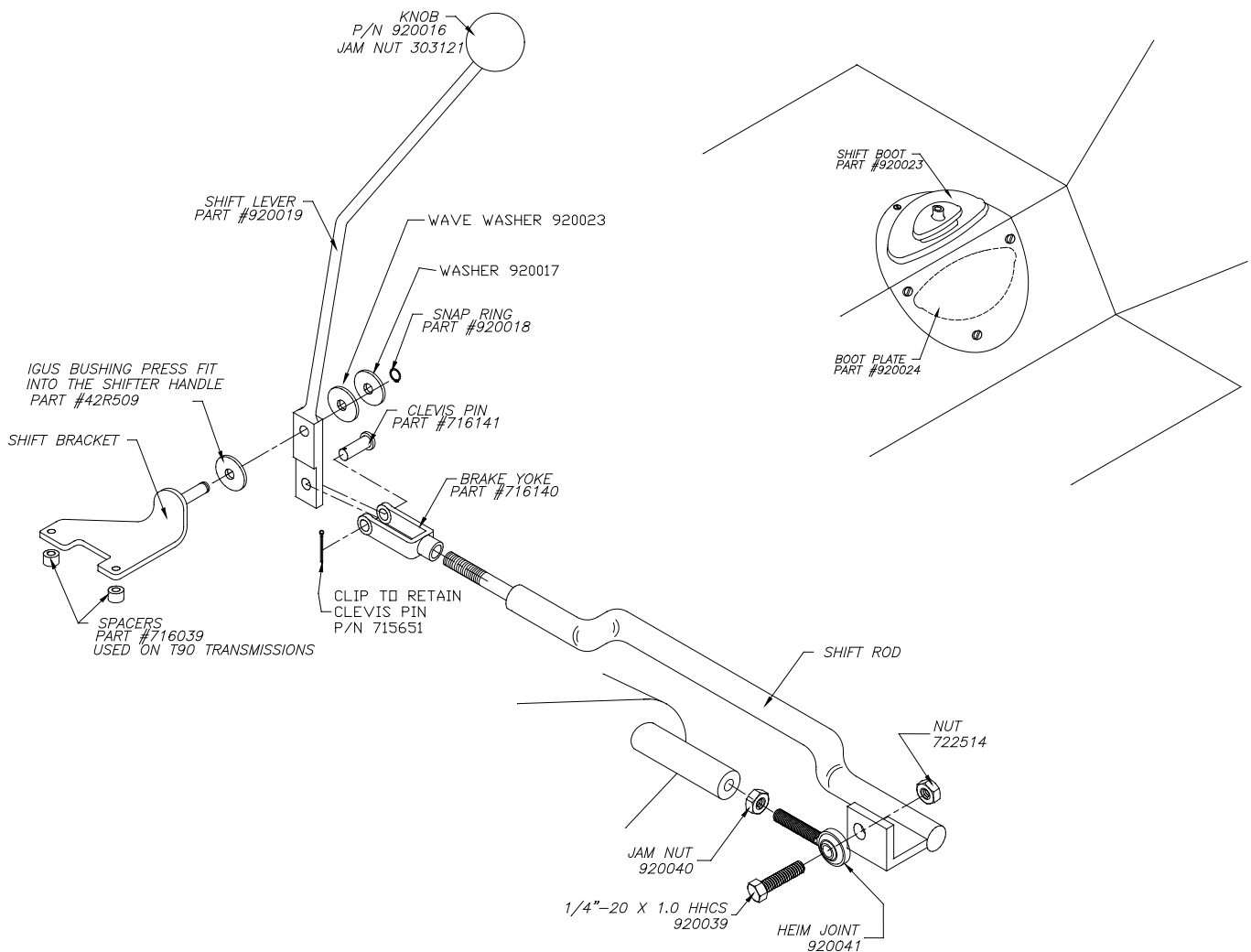

SPECIAL NOTE: The components packaged in this kit have been assembled and machined for specific type of conversions. Modifications to any of the components will void any possible warranty or return privileges. If you do not fully understand modifications or changes that will be required to complete your conversion, we strongly recommend that you contact our sales department for more information. This instruction sheet is only to be used for the assembly of Advance Adapter components. We recommend that a service manual pertaining to your vehicle be obtained for specific torque values, wiring diagrams and other related equipment. These manuals are normally available at automotive dealerships and parts stores.