

ADVANCE ADAPTERS INC.

P.O. Box 247, 4320 Aerotech Center Way

Paso Robles, CA 93447

Telephone: (800) 350-2223 Fax: (805) 238-4201

P/N: 716038

PAGE 1 OF 1

Page Rev. Date: 07-13-15

GM 32T INPUT GEAR FOR NEW PROCESS TRANSFER CASES

KIT CONSISTS OF:

No.	Qty	Part No.	Description
1.	1	716044	INPUT GEAR WITH 32T INTERNAL SPLINES, BEARING AND SNAPRINGS

NOTES:

This input gear is a two piece gear similar to the stock Chevrolet item that was used on the 1-ton truck applications. By using this special input gear, you will be able to use an stock 2WD output shaft from various types of transmissions. These transmissions could be the GM TH400, or possibly the New Venture 4WD version-NV4500. The larger sleeve will require the use of the larger bearing. When replacing a TH350 or SM465 input gear on Chevy transfer cases, you will need to disassemble and machine the bearing bore in the transfer case to the larger size. The average cost for the machine work is approximately \$100.00. On Ford applications, the machining requirement for the bearing is not required since Ford uses the larger diameter. Adapter plates or housings will need to have the bearing bore and snap ring diameter changed.

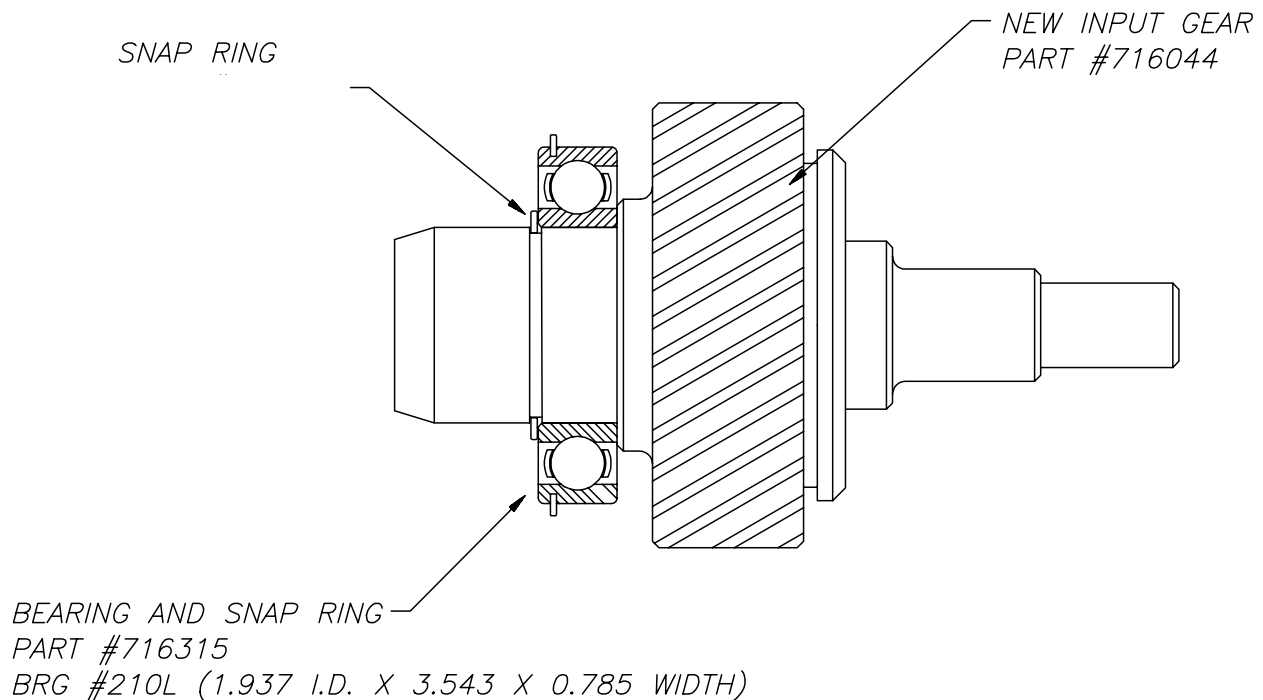

SPECIAL NOTE: The components packaged in this kit have been assembled and machined for specific type of conversions. Modifications to any of the components will void any possible warranty or return privileges. If you do not fully understand modifications or changes that will be required to complete your conversion, we strongly recommend that you contact our sales department for more information. This instruction sheet is only to be used for the assembly of Advance Adapter components. We recommend that a service manual pertaining to your vehicle be obtained for specific torque values, wiring diagrams and other related equipment. These manuals are normally available at automotive dealerships and parts stores.