

ADVANCE ADAPTERS INC.

P.O. Box 247, 4320 Aerotech Center Way

Paso Robles, CA 93447

Telephone: (800) 350-2223 Fax: (805) 238-4201

P/N: 713008-NS

PAGE 1 OF 1

Page Rev. Date: 09-04-15

ENGINE MOUNTING HARDWARE

KIT CONSISTS OF:

No.	Qty	Part No.	Description
1.	4	716656	LARGERUBBER MOUNT
2.	1	713008-B	BOLT PACK FOR 713008-NS
			kit includes: 2-726202
			4-726207
			2-726209

NOTE: The early Advance Adapters frame brackets were a 3/16" material. Today we use a 1/4" material. If your brackets are the thinner 3/16" material, you will notice the two rubber mounts will interfere with each other when installing. On these applications you must grind 1/16" off the indexing hub of the rubber mount so they do not interfere.

THE 5/8"-18 NYLON NUT SHOULD BE TORQUED TO 25 TO 30 FT./LBS.

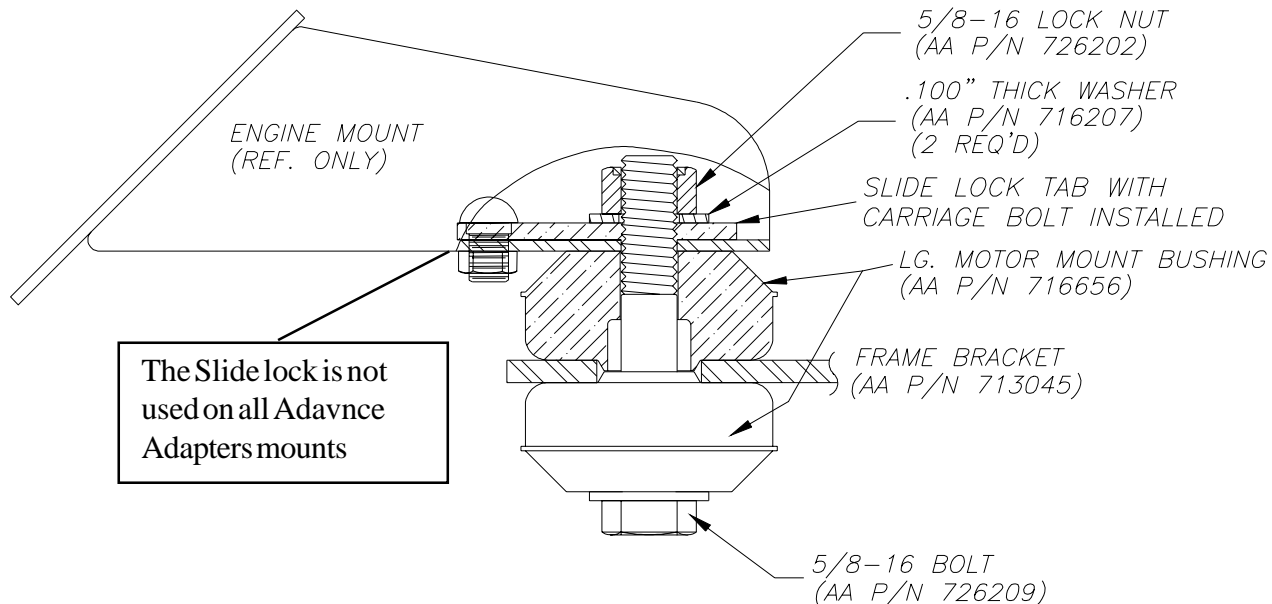

SPECIAL NOTE: The components packaged in this kit have been assembled and machined for specific type of conversions. Modifications to any of the components will void any possible warranty or return privileges. If you do not fully understand modifications or changes that will be required to complete your conversion, we strongly recommend that you contact our sales department for more information. This instruction sheet is only to be used for the assembly of Advance Adapter components. We recommend that a service manual pertaining to your vehicle be obtained for specific torque values, wiring diagrams and other related equipment. These manuals are normally available at automotive dealerships and parts stores.