

# ADVANCE ADAPTERS INC.

P.O. Box 247, 4320 Aerotech Center Way  
Paso Robles, CA 93447

Telephone: (800) 350-2223 Fax: (805) 238-4201

## P/N: 50-2602

Old Part No: 711026NS-16  
PAGE 1 OF 3

Page Rev. Date: 02-14-03

## GM TRUCK 4SP MODEL SM420 TO TOYOTA L/C 4 SPEED TRANSFER CASE

### KIT CONSISTS OF:

No.	Qty	Part No.	Description
1.	1	51-1200	CASTING (4.5" LG.) (Ref: 711112)
2.	1	52-4601	SPUD SHAFT W/16 TOOTH (Ref: 711346-16)
3.	1 KIT	715527	TRANSFER CASE SHIFTER BRKT.
4.	1	716013	BEARING RETAINER
5.	1	716301	BEARING
6.	1	716453	SNAPRING
7.	1	716454	SET COLLAR
8.	1	716568	GASKET
9.	1	716508	GASKET (GM #384-9472)
10.	1	723701	3/8"-16 HEX NUT
11.	1	723714	3/8"-16 X 1-1/2" STUD BOLT
12.	7	723722	H.H.C.S. 3/8"-16 X 1-1/4" LG.
13.	3	724345	H.H.C.S. 7/16"-14 X 5" LG.
14.	2	724349	H.H.C.S. 7/16"-14 X 1-1/2" LG.
15.	1	728701	NYLON LOCK NUT
16.	1	728702	7/8" FLAT WASHER

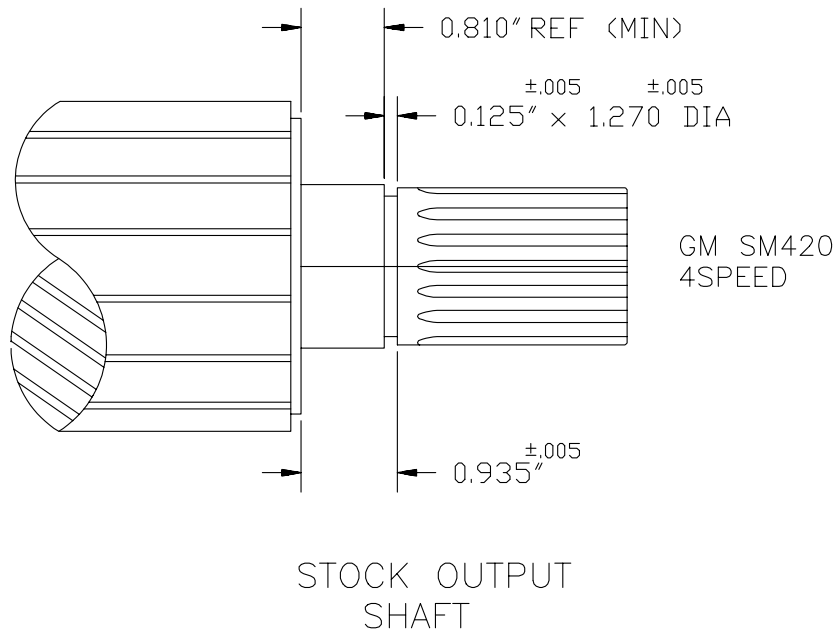

**SPECIAL NOTE:** The components packaged in this kit have been assembled and machined for specific type of conversions. Modifications to any of the components will void any possible warranty or return privileges. If you do not fully understand modifications or changes that will be required to complete your conversion, we strongly recommend that you contact our sales department for more information. This instruction sheet is only to be used for the assembly of Advance Adapter components. We recommend that a service manual pertaining to your vehicle be obtained for specific torque values, wiring diagrams and other related equipment. These manuals are normally available at automotive dealerships and parts stores.

# ADVANCE ADAPTERS INC.

P.O. Box 247, 4320 Aerotech Center Way  
Paso Robles, CA 93447

Telephone: (800) 350-2223 Fax: (805) 238-4201

**P/N: 50-2602**

Old Part No: 711026NS-16  
PAGE 2 OF 3

Page Rev. Date: 12-16-99

## GM TRUCK 4SP MODEL SM420 TO TOYOTA L/C 4 SPEED TRANSFER CASE

### GM & CHEVY SM420 TRUCK 4 SPEED 1948-1967:

This transmission can be identified by a case length of 10-1/2". The casting numbers on the side of the case should be GM3761930 or GM3813389. The transmission has a shift cover that bolts over the top of the transmission that has a shift cover part number of GM591568. The P.T.O. opening is on the left hand side of the main case and the transmission has a non-synchro first gear.

The transmission you select can either be disassembled and machined for a snap ring that will retain the rear main bearing, or the new set collar we supply in the adapter kit can be used in place of the snap ring. If this set collar is installed properly, it will do the same job as the snap ring. Make sure the collar and the clamp screw secure the shaft from any forward movement. The drawing will illustrate the dimensional data for installation of a groove that must be cut into the shaft for holding the rear bearing in position. There are a few stock applications where this snap ring will already be in place and the transmission will not need the new snap ring or set collar.

The right side of the main case will need to be ground off for clearance of the front output yoke on certain installations. We recommend a trial fit with your transfer case and front output yoke so that any modifications that may be required can be done before final installation into the vehicle. This is also a good time to set up the shifter linkage for the transfer case controls.

The early Chevy truck 4 speeds were equipped with the small front bearing retainer that is 4.686" in diameter and must be used with either early truck bellhousings or late model car-type bellhousings. The late model truck bellhousings all use a 5-1/8" retainer size that will not be compatible with this transmission.

We changed the design of these SM420 kits to incorporate a spud shaft design in 1988. Prior to this time, we manufactured a completely new main shaft for all SM420 transmission conversions.

<b>First Gear</b>	7.05
<b>Second Gear</b>	3.57
<b>Third Gear</b>	1.70
<b>Fourth Gear</b>	Direct

**REFERENCE ONLY:** May 1992 adapter housing increased in length to 4-1/2" and coupler Part No. 711326-16 was changed to 52-4601. This change was made to increase spline contact onto output shaft of SM420 transmission.

**SPECIAL NOTE:** The components packaged in this kit have been assembled and machined for specific type of conversions. Modifications to any of the components will void any possible warranty or return privileges. If you do not fully understand modifications or changes that will be required to complete your conversion, we strongly recommend that you contact our sales department for more information. This instruction sheet is only to be used for the assembly of Advance Adapter components. We recommend that a service manual pertaining to your vehicle be obtained for specific torque values, wiring diagrams and other related equipment. These manuals are normally available at automotive dealerships and parts stores.

# ADVANCE ADAPTERS INC.

P.O. Box 247, 4320 Aerotech Center Way  
Paso Robles, CA 93447

Telephone: (800) 350-2223 Fax: (805) 238-4201

## P/N: 50-2602

Old Part No: 711026NS-16  
PAGE 3 OF 3

Page Rev. Date: 12-16-99

## GM TRUCK 4SP MODEL SM420 TO TOYOTA L/C 4 SPEED TRANSFER CASE

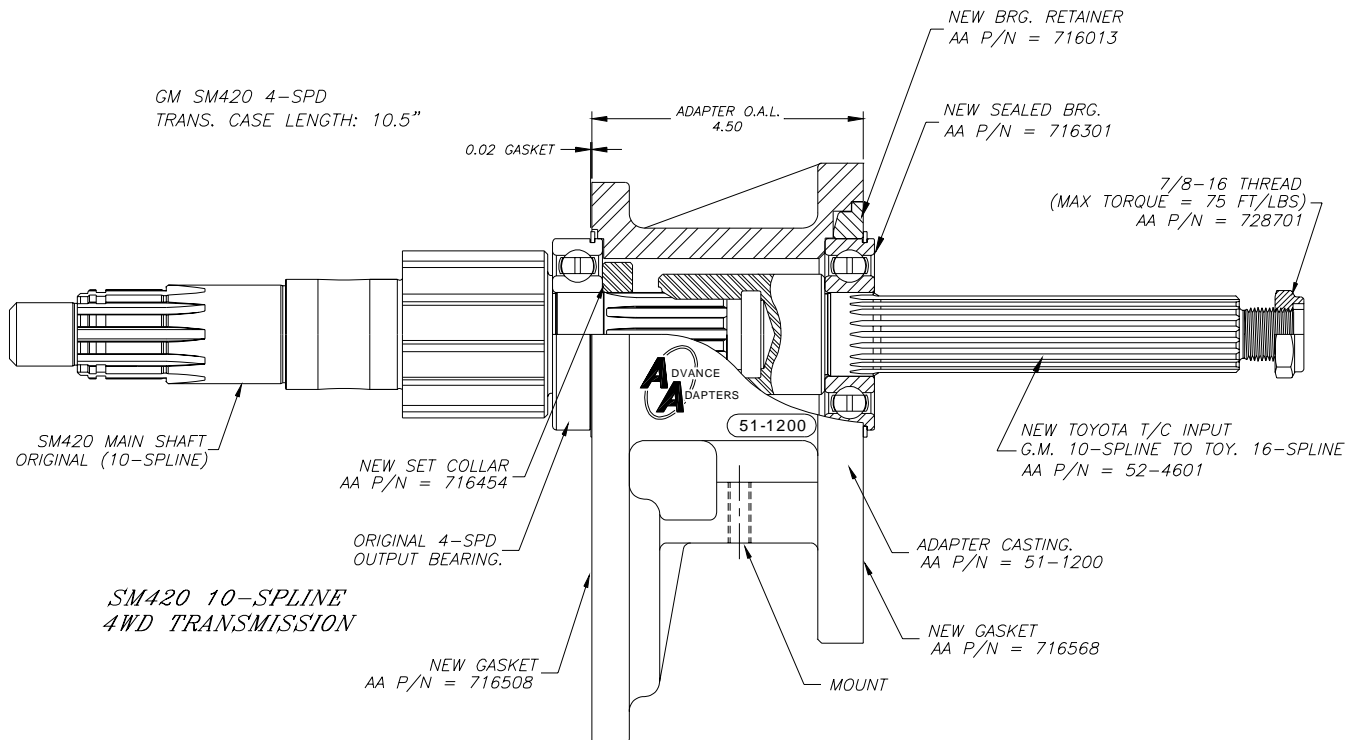

**SPECIAL NOTE:** The components packaged in this kit have been assembled and machined for specific type of conversions. Modifications to any of the components will void any possible warranty or return privileges. If you do not fully understand modifications or changes that will be required to complete your conversion, we strongly recommend that you contact our sales department for more information. This instruction sheet is only to be used for the assembly of Advance Adapter components. We recommend that a service manual pertaining to your vehicle be obtained for specific torque values, wiring diagrams and other related equipment. These manuals are normally available at automotive dealerships and parts stores.