



P.O. Box 247, 4320 Aerotech Center Way
Paso Robles, CA 93447
Telephone: (800) 350-2223 Fax: (805) 238-4201
PAGE 1 OF 3 Page Rev. Date: 08-08-19
P/N: 50-5310

GM 4L60E ADAPTER TO GM NP205 27 SPLINE

KIT CONSISTS OF:

No.	Qty.	Part No.	Description
1.	1	51-0405	4L60E / UNIVERSAL ADAPTER
2.	1	51-5302A	TH350 TO NP205 CASTING
3.	1	52-6900	700R-4 OUTPUT SHAFT (Ref: 711369)
4.	1	52-9503B	COUPLER- GM 27SP TRANS X GM 27SP TC
5.	1	300619	RELECTOR SENSOR
6.	1	716072	RELECTOR RING CLAMP RING (One piece reluctor, bolt torque 10 ft-lbs.)
7.	1	716079	22mm PLUG
8.	1	716082	700R PLASTIC WASHER
9.	1	716511	"O"-RING
10.	2	716745	NEW SEAL FOR ADAPTER HOUSING (<i>Installed by AA</i>)
11.	1	716572	NP205 GASKET
12.	2	720046	10mm-1.5 THR X 40mm S.H.C.S. METRIC BOLTS
13.	2	720074	10mm-1.5 THR X 45mm S.H.C.S. METRIC BOLTS

In 1996, GM produced a newer version of its electronically controlled 4L60E. This 4L60E transmission is 21-1/2" long, and has a removable bellhousing. It has a hex bolt pattern on the output side of the transmission, similar to a TH400.

The 51-0405 adapter was designed to make this style of 4L60E look just like a 700R. By incorporating a new clamp-on reluctor ring and sensor on this adapter, a 40 pulse per output shaft revolution signal is generated for the drivetrain control module. This adapter kit comes with a new clamp-on reluctor ring that should be installed on the new 700R output shaft that is also part of this kit. This clamp-on reluctor ring clamps over the stock governor gear on the 700R output shaft. We have provided two reluctor sensor locations to choose from in the adapter. The hole not being used will need to be plugged with the plug provided.

Before tightening this clamp, trial fit the 51-0405 adapter plate onto the back of the 4L60E transmission. With the adapter set on the back of the transmission, install the 300619 reluctor sensor into the adapter casting. The 300619 sensor should line up over the teeth of the reluctor clamp. When you obtain this location, remove the adapter housing, making sure not to disturb the position of the clamp on the shaft. With the clamp now exposed, tighten the set screws on the clamp. *Loctite on these set screws is recommended.*

Trial fit the 51-0405 adapter and 300619 sensor back on the transmission and make sure the reluctor ring teeth and sensor still line up properly. *RTV Blue Silicone* should be used to seal the 51-0405 adapter to your 4L60E transmission. Screw the 300619 sensor completely into the 51-0405 casting. With a feeler gauge, check the gap between the sensor and the reluctor ring. This gap should be around 0.010" to 0.012". Once 0.010" to 0.012" clearance is obtained, loc-tite the sensor into position.

SPECIAL NOTE: The components packaged in this kit have been assembled and machined for a specific type of conversion. Modifications to any of the components will void any possible warranty or return privileges. If you do not fully understand the modifications or changes that will be required to complete your conversion, we strongly recommend that you contact our sales department for more information. This instruction sheet is only to be used for the assembly of Advance Adapter components. We recommend that a service manual pertaining to your vehicle be obtained for specific torque values, wiring diagrams and other related equipment. These manuals are normally available at automotive dealerships and parts stores. Always inspect parts prior to installation for consistency with the OEM offering (e.g., spline count, tooth count, lubrication points, etc.).

GM 4L60E ADAPTER TO GM NP205 27 SPLINE

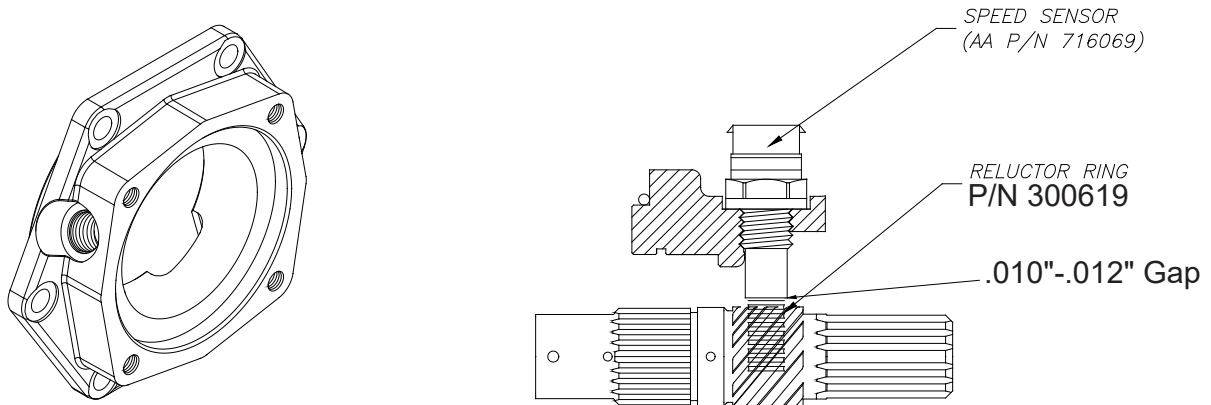

Sensor note: The sensor in this kit was changed in October 2005. This sensor will match up with the GM pigtail P/N 12162193 or Carquest P/N TX3A. The old sensor used in earlier kits matches up to GM pigtail P/N 12085498.

When assembling the 51-5302A adapter housing to the 51-0405 adapter, we have provided you with a new square type "O" ring seal to prevent fluid leakage. This seal is a stock GM item that is used on all 700R-4 installations.

Some of the stock NP205 transfer cases used a large C.V. yoke assembly that may interfere with the 4L60E transmission pan. You may be required to replace your transfer case yoke & driveshaft assemblies.

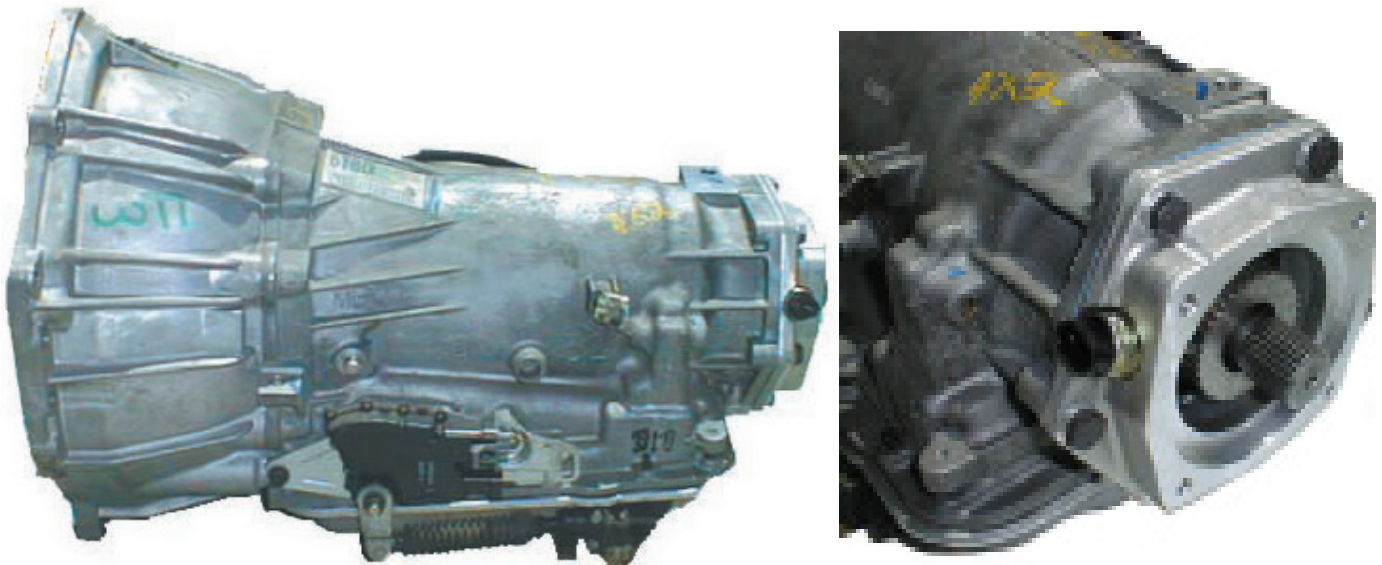

SPECIAL NOTE: The components packaged in this kit have been assembled and machined for a specific type of conversion. Modifications to any of the components will void any possible warranty or return privileges. If you do not fully understand the modifications or changes that will be required to complete your conversion, we strongly recommend that you contact our sales department for more information. This instruction sheet is only to be used for the assembly of Advance Adapter components. We recommend that a service manual pertaining to your vehicle be obtained for specific torque values, wiring diagrams and other related equipment. These manuals are normally available at automotive dealerships and parts stores. Always inspect parts prior to installation for consistency with the OEM offering (e.g., spline count, tooth count, lubrication points, etc.).

GM 4L60E ADAPTER TO GM NP205 27 SPLINE

This kit is intended For GM vehicles 1971-1979 that were equipped with a TH350 transmission and a New Process 205 transfer case. This housing is a direct replacement for the stock cast iron housing. The stock housing was subject to breakage on the foot of the casting. We have provided two new seals and gaskets for installation of this adapter.

There are two styles of this casting used from GM. One used a bearing supported coupler sleeve, and the second used a coupler sleeve that was centered by the male splines of the transfer case and transmission. This kit is designed to use the coupler that is centered on the transmission and transfer case splines.

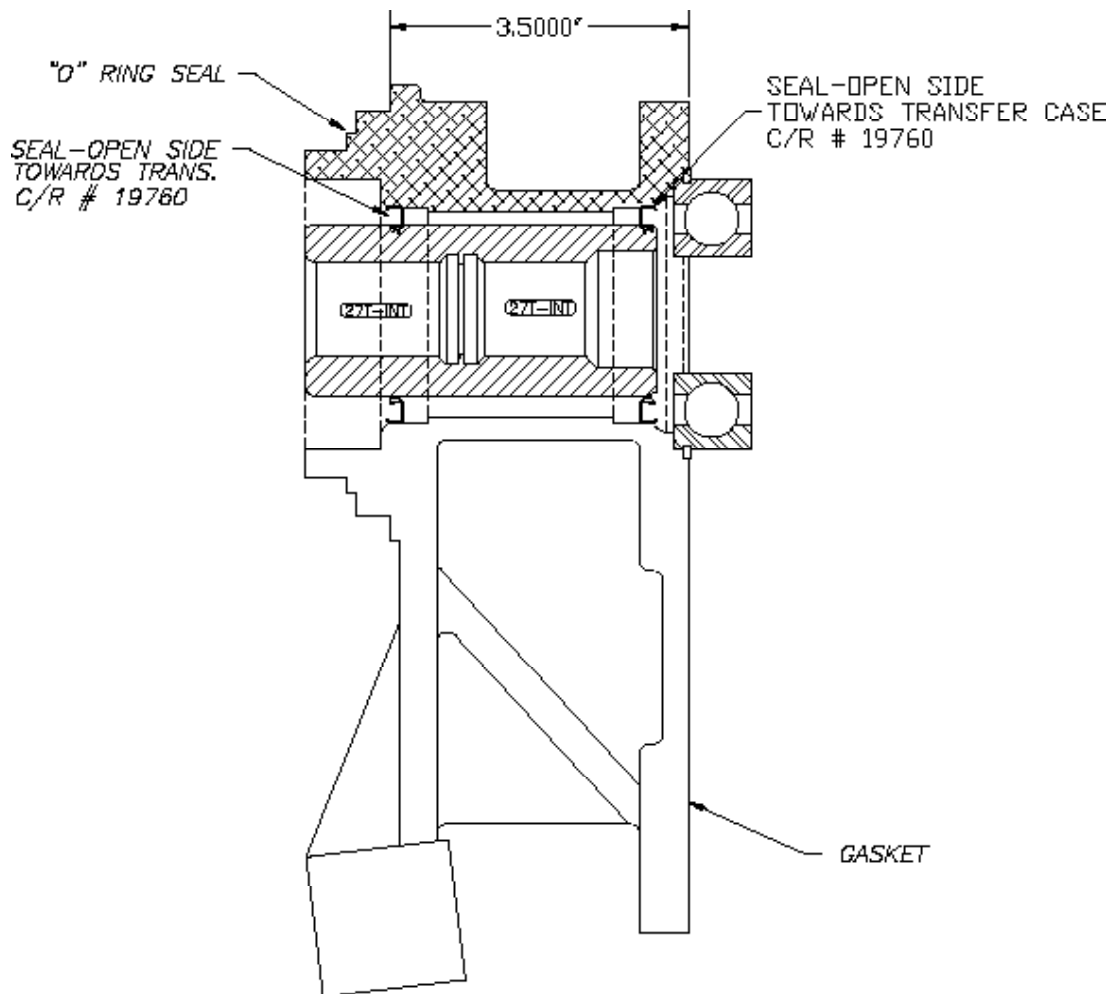

SPECIAL NOTE: The components packaged in this kit have been assembled and machined for a specific type of conversion. Modifications to any of the components will void any possible warranty or return privileges. If you do not fully understand the modifications or changes that will be required to complete your conversion, we strongly recommend that you contact our sales department for more information. This instruction sheet is only to be used for the assembly of Advance Adapter components. We recommend that a service manual pertaining to your vehicle be obtained for specific torque values, wiring diagrams and other related equipment. These manuals are normally available at automotive dealerships and parts stores. Always inspect parts prior to installation for consistency with the OEM offering (e.g., spline count, tooth count, lubrication points, etc.).