

1-1/8" JEEP DANA 18/20 TRANSFER CASE INTERMEDIATE GEAR KIT

KIT CONSISTS OF:

No.	Qty	Part No.	Description
1.	1	716026	SHAFT
2.	1	716027	BUSHING
3.	2	716304	BEARING CUPS
4.	2	716305	BEARING CONES
5.	1	716709	"O"-RING
6.	1	716710	"O"-RING
7.	1	720005	PIN
8.	1	726207	WASHER
9.	1	726201	NUT

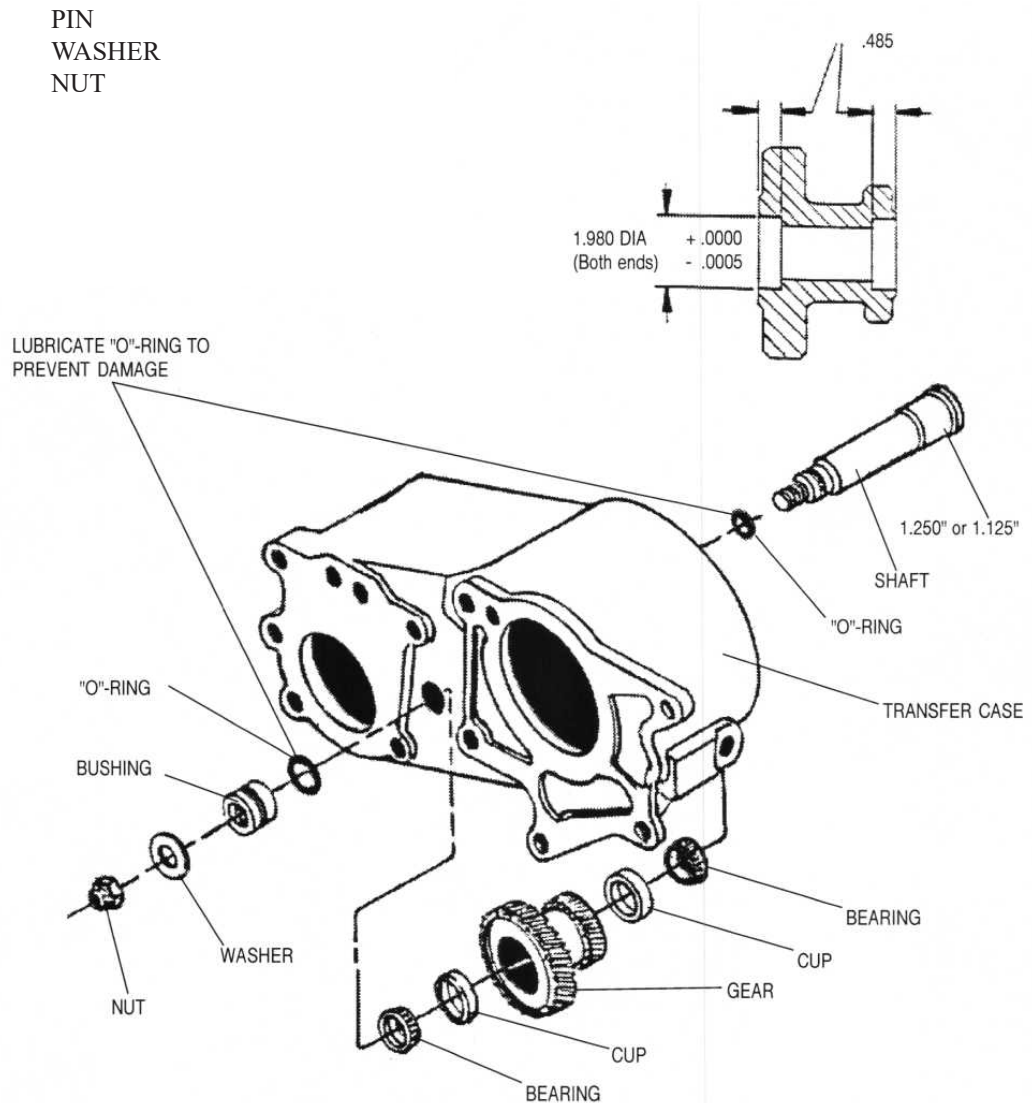

SPECIAL NOTE: The components packaged in this kit have been assembled and machined for specific type of conversions. Modifications to any of the components will void any possible warranty or return privileges. If you do not fully understand modifications or changes that will be required to complete your conversion, we strongly recommend that you contact our sales department for more information. This instruction sheet is only to be used for the assembly of Advance Adapter components. We recommend that a service manual pertaining to your vehicle be obtained for specific torque values, wiring diagrams and other related equipment. These manuals are normally available at automotive dealerships and parts stores.



P.O. Box 247, 4320 Aerotech Center Way
Paso Robles, CA 93447
Telephone: (800) 350-2223 Fax: (805) 238-4201
PAGE 2 OF 2 Page Rev. Date: 09-06-18
P/N: 716006

1-1/8" JEEP DANA 18/20 TRANSFER CASE INTERMEDIATE GEAR KIT

INSTALLATION INSTRUCTIONS:

Counter bore each side of gear to 1.9800 - 1.9795" diameter to a depth of .480/.485", and make sure stock bore runs concentric before boring each side. Due to the extreme hardness of the gear, several cuts will need to be made in order to obtain the correct measurements.

This specifically designed intermediate gear is manufactured for a quick and simple installation. The unit once installed, will eliminate some of the excessive noise and will reduce heating problems. The design utilizes the same principal as the wheel bearings on an automobile. Unlike the stock setup, this gear can be serviced without replacing the gear itself. The stock setup will normally need to have the complete gear replaced since the race for the bearing is the actual gear. With our design, the cups can be replaced.

1. Remove front universal joint from rear driveshaft.
2. Remove parking brake drum and plate.
3. Drain transfer case.
4. Remove transfer case pan.
5. Remove bolt on rear side of case that prevents shaft from rotating.
6. Remove the old shaft by driving it out towards the rear of the vehicle.
7. Remove gear, needle bearing, and washers.
8. Place new gear in position as illustrated. Make sure cones are not damaged in shipment and are in position.
9. Slide shaft into gear assembly making sure the threaded end is pointing towards the engine. The shaft should slip on most of the way by hand. The last portion of the shaft will need to be driven into the transfer case with approximately the same force that was required to remove the old shaft.
10. The flat washer may need a flat ground on it to clear the transfer case bolt pattern. Install the bushing, the flat washer, and nut onto the new shaft. Snug the nut 1 or 2 notches and check gear for side load and freeness. This is identical to the procedure for setting up a wheel bearing.
11. Replace cover, bolt for end of shaft and brake parts.
12. Refill transfer case with oil.
13. The new gear should be checked every 15,000 miles for bearing wear and to set taper bearing adjustment.

SPECIAL NOTE: The components packaged in this kit have been assembled and machined for specific type of conversions. Modifications to any of the components will void any possible warranty or return privileges. If you do not fully understand modifications or changes that will be required to complete your conversion, we strongly recommend that you contact our sales department for more information. This instruction sheet is only to be used for the assembly of Advance Adapter components. We recommend that a service manual pertaining to your vehicle be obtained for specific torque values, wiring diagrams and other related equipment. These manuals are normally available at automotive dealerships and parts stores.