



P.O. Box 247, 4320 Aerotech Center Way  
Paso Robles, CA 93447  
Telephone: (800) 350-2223 Fax: (805) 238-4201  
PAGE 1 OF 2 Page Rev. Date: 11-08-21  
P/N: 50-6409

## GM 4L80E AUTOMATIC TO ATLAS 2 SPEED TRANSFER CASE

### KIT CONSISTS OF:

No.	Qty	Part No.	Description
1.	1	51-6409	ADAPTER SPACER w/ VSS
2.	1	300619	GM VEHICLE SPEED SENSOR (TORQUE SENSOR TO 20 IN./LBS.)
3.	6	723766	3/8"-16 x 2" S.H.C.S. (FOR BOLTING THE 51-6409 TO THE ATLAS)
4.	1	300623	RELUCTOR RING MODIFIED
5.	3	300617A	SET SCREWS FOR THE RELUCTOR RING

### GM 4L80E 4 SPEED AUTOMATIC OVERDRIVE- BACKGROUND INFORMATION

The GM 4L80E has a case length of 26" and has 17 bolts for retaining the oil pan. The rear side of the transmission case will have a hex shaped bolt pattern that uses 6 bolts. There are several different lengths of output shafts that the transmission has been equipped with, but **THIS KIT REQUIRES A 4WD OUTPUT SHAFT.**

The 4L80E transmission is normally equipped with an internal reluctor ring on both the transmissions input shaft and output shaft. The computer needs both of these readings for the proper shifting and operation of this transmission. The rear reluctor ring is not always installed into the transmission. The basic rule of thumb is 4WD transmissions up to 1996 should have a rear reluctor ring in the main transmission case. All 2WD transmissions should have the rear reluctor in the main transmission case. The 1997 & newer 4WD 4L80E transmissions had a sensor provision; however, the reluctor ring in the transmission was left out. Since it is expensive to disassemble the transmission to add a reluctor ring, this kit has a vehicle speed sensor built in that can be used in place of the 4L80E Output Shaft Speed Sensor.

**Note:** The information on years and models of the 4L80E transmission mentioned in the above section is obtained from various sources. You should always verify what your transmission is equipped with before beginning a conversion with the 4L80E transmission.

The reluctor ring will need to be slipped onto the Atlas input. Before tightening the set screws, Trial fit the 51-6409 adapter onto the front of the Atlas (the rotation does not matter at this time). With the adapter set on the transfer-case, install the 300619 reluctor sensor into the adapter casting. Locate The 300623 reluctor with the set screws facing towards the transmission and the 40 teeth centered with the sensor. Note: This gap between the reluctor and the sensor should be around 0.010" to 0.012". Once the gap is confirmed and the location of the reluctor is obtained you can remove the adapter housing, making sure not to disturb the position of the clamp on the shaft. With the clamp now exposed, tighten the set screws to clamp the reluctor to the Atlas input shaft. [Loctite on these set screws is recommended.](#)

Determine the correct transfer case rotation for your application and then bolt the 51-6450 casting to the Atlas. Bolt the 51-6450 casting to the rear of the 4L80E using the new bolts. Make sure that the 4L80E output shaft and the Atlas input shaft do not bottom out. **DO NOT FORCE THE ADAPTERS TOGETHER.** If assistance is needed, please feel free to call the phone number listed above.

**Note on gap adjustment:** This clearance should be 0.012" +/- 0.002". This clearance may be adjusted slightly by adjusting torque used to snug the sensor. The transmission will not shift correctly if this tolerance is not correct.

Bolt the 51-6408 casting to the rear of the 4L80E using the stock fasteners. Note: The stud located at 6 O'clock may need to be shorten to clear the transmission pan. Torque to 25 ft./lbs.

Determine the correct transfer case rotation for your application and then bolt the 51-6409 casting to the Atlas.

**SPECIAL NOTE:** The components packaged in this kit have been assembled and machined for specific type of conversions. Modifications to any of the components will void any possible warranty or return privileges. If you do not fully understand modifications or changes that will be required to complete your conversion, we strongly recommend that you contact our sales department for more information. This instruction sheet is only to be used for the assembly of Advance Adapter components. We recommend that a service manual pertaining to your vehicle be obtained for specific torque values, wiring diagrams and other related equipment. These manuals are normally available at automotive dealerships and parts stores.

## GM 4L80E AUTOMATIC TO ATLAS 2 SPEED TRANSFER CASE

Thread the 6 studs (included with your transfer case) completely into the 51-6409 casting. You are now ready to bolt the transfer case (51-6409) casting to the 4L80E (51-6408) casting. When assembling these components, make sure that the 4L80E output shaft and the Atlas input shaft do not bottom out. **DO NOT FORCE THE ADAPTERS TOGETHER.** If assistance is needed, please feel free to call the phone number listed above. Once the two adapters and completely engaged, use the 6-3/8" serrated nuts (included with your transfer case) to tighten the adapters together.

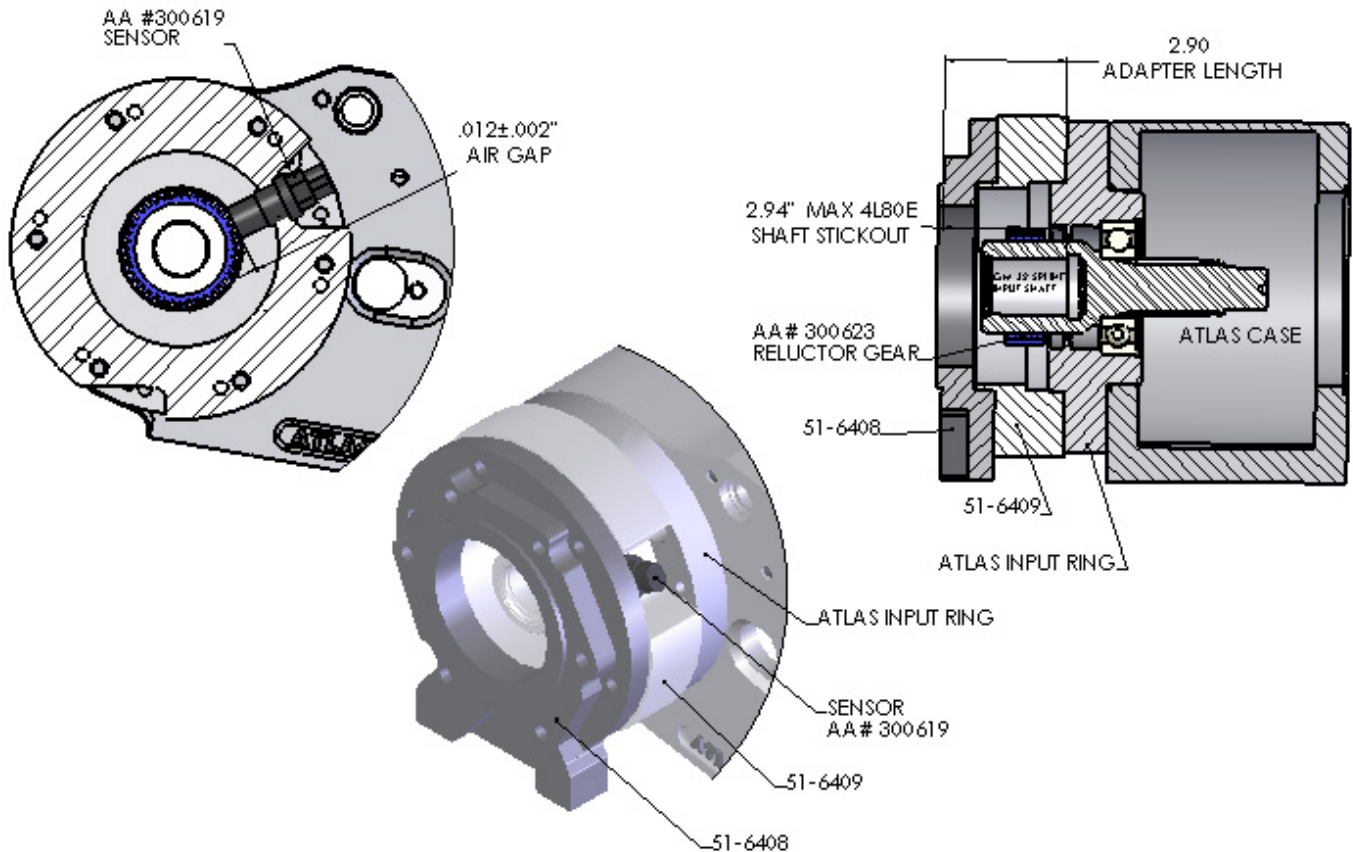

**SPECIAL NOTE:** The components packaged in this kit have been assembled and machined for specific type of conversions. Modifications to any of the components will void any possible warranty or return privileges. If you do not fully understand modifications or changes that will be required to complete your conversion, we strongly recommend that you contact our sales department for more information. This instruction sheet is only to be used for the assembly of Advance Adapter components. We recommend that a service manual pertaining to your vehicle be obtained for specific torque values, wiring diagrams and other related equipment. These manuals are normally available at automotive dealerships and parts stores.