



P.O. Box 247, 4320 Aerotech Center Way
 Paso Robles, CA 93447
 Telephone: (800) 350-2223 Fax: (805) 238-4201
 PAGE 1 OF 3 Page Rev. Date: 10-16-18
 P/N: 715569

TOYOTA L/C FJ60/62 TRANSFER CASE TWIN STICK UNIVERSAL KIT

KIT CONSISTS OF:

No:	Qty	Part No.	Description
1.	1 Kit	715570R	RANGE SHIFTER HANDLE <i>(Kit Consists of 715586A, 715575)</i>
2.	1	715577	MODE PIVOT BLOCK
3.	1	715586A	MODE & RANGE HANDLE (STR)
4.	1	715588E	ELBOW- MODE SHIFT ROD (FJ60)
5.	1	302060	BOOT- TWIN STICK
6.	1	302063	BOOT RING- ATLAS TWIN STICK
7.	1	302203	ROD END-FEMALE 5/16" RH
8.	2	303121	NUT-1/2-13 HX JAM BLACK ZINC
9.	1	715576	T-CASE HI/LOW SHIFT LEVER
10.	1	715579	TLC TWIN STICK PIVOT SHAFT
11.	2	715580	ROD END-FEMALE 3/8"-24 W/STUD HIGH/LOW SHIFT
12.	1	715582	ROD END-MALE 5/16"-24 RH PTFE
13.	1	715584AA	KNOB-BLACK SHIFT KNOB SET
14.	1	715585A	SHAFT- TOYOTA SPLIT CASE TWIN STICK MODE
15.	1	715589	CLEVIS PIN 5/16" x 1-1/8" LONG
16.	1	715590	COTTER PIN 3/32" X 1"
17.	4	715591	BUSHING-TWIN STICK PIVOT
18.	1	723101	NUT 5/16"-18 PLATED
19.	1	723103	LOCK WASHER 5/16" PLATED
20.	1	723122	USS PLATED 5/16 FLAT WASHER
21.	1	723131	5/16"-24 HEX JAM NUT zinc
22.	2	723719	HEX JAM NUT 3/8"-24 PLATED
23.	1	723769	3/8"-24 X 3/8" CUP POINT Socket Set Screw
24.	1	723771	STUD BOLT- 3/8"-24 X 9"
25.	1	723136	5/16"-24 X 1" H.H.C.S. GRD8 NO PLATE

****715591 IS A PRESS FIT INTO THE PIVOT BLOCK**

NOTES:

This assembly will require the installation of a new mode shaft into the transfer case. Refer to the exploded assembly view on the following pages for part identification and part assembly.

SPECIAL NOTE: The components packaged in this kit have been assembled and machined for specific type of conversions. Modifications to any of the components will void any possible warranty or return privileges. If you do not fully understand modifications or changes that will be required to complete your conversion, we strongly recommend that you contact our sales department for more information. This instruction sheet is only to be used for the assembly of Advance Adapter components. We recommend that a service manual pertaining to your vehicle be obtained for specific torque values, wiring diagrams and other related equipment. These manuals are normally available at automotive dealerships and parts stores.

TOYOTA L/C FJ60/62 TRANSFER CASE TWIN STICK UNIVERSAL KIT

INSTALLATION OF PART #715585:

This kit requires the installation of a new mode selector shaft into your stock transfer case. Refer to a transfer case service manual for the proper installation and removal on this shaft.

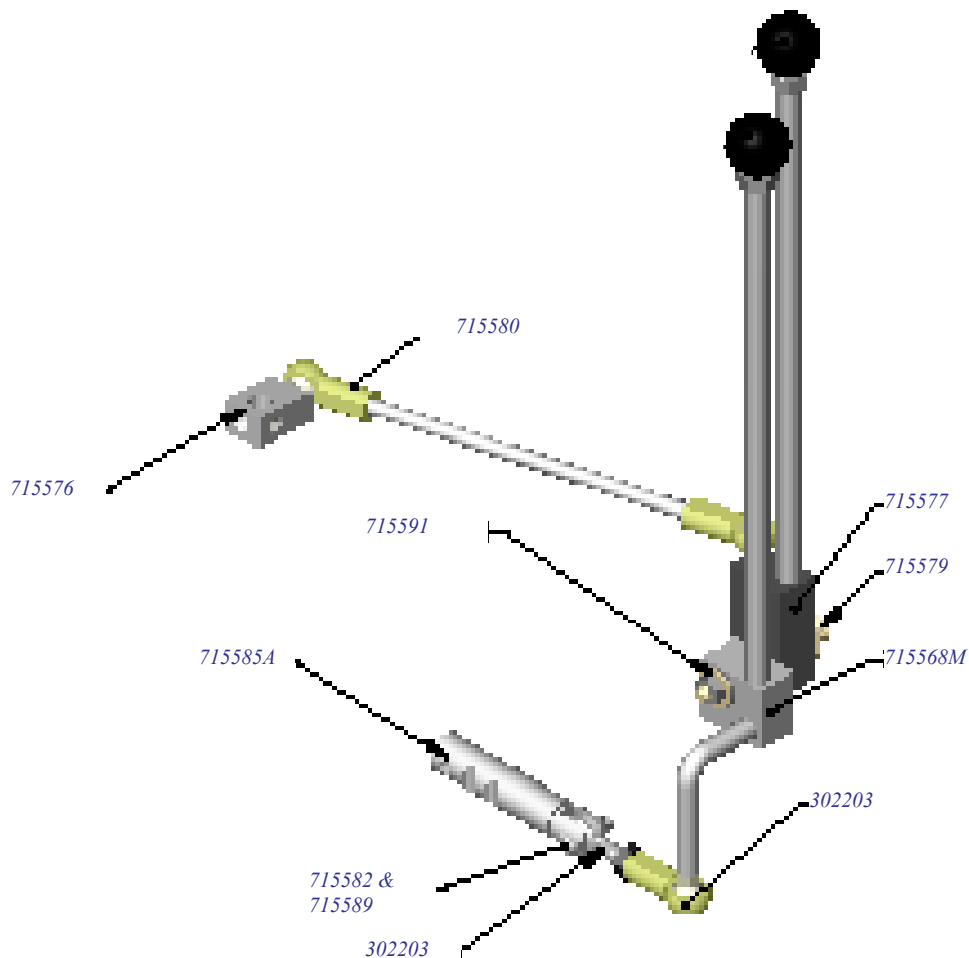

SPECIAL NOTE: The components packaged in this kit have been assembled and machined for specific type of conversions. Modifications to any of the components will void any possible warranty or return privileges. If you do not fully understand modifications or changes that will be required to complete your conversion, we strongly recommend that you contact our sales department for more information. This instruction sheet is only to be used for the assembly of Advance Adapter components. We recommend that a service manual pertaining to your vehicle be obtained for specific torque values, wiring diagrams and other related equipment. These manuals are normally available at automotive dealerships and parts stores.

TOYOTA L/C FJ60/62 TRANSFER CASE TWIN STICK UNIVERSAL KIT

INSTALLATION:

Install the transfer case high/low shifter arm to the top cover of the transfer case. Since Land Cruisers had two shaft configurations, we have provided two tapped holes on this lever. Match the tapped hole with the flat portion of the shaft.



Temporarily install the pivot shaft and both shift blocks (P/N 715570 & 715577) onto the Advance Adapters bracket. These two blocks should be pointing straight up at the middle of their range. Paying attention to the orientation of the blocks and where the stock hole in the floor is located, carefully bend the shift handles (P/N 715586A) to fit your particular application. Make sure the handles clear each other as they travel along their path. It may be necessary at this point to enlarge the hole in the floor to gain clearance for both handles.

Now weld the mode handle to its corresponding shift block, as shown. Mode shift link P/N 715588E comes pre-bent, but the distance it sticks out of the mode block (P/N 715577) needs to be set for your application. Weld the mode shift link to the mode block so that it is in-line with the mode shaft (P/N 715585A) and so that the link is parallel to the long edge of the block (straight down). See pictures "vertical alignment" and "horizontal alignment" below for a visual description. Note that the mode shift link may need to be cut on the non-threaded end to achieve the desired alignment.

Hold the shift handles in place and mark the floor for necessary modifications. We have designed the handles to come up through the stock hole in the floor with only slight modifications needed to change the shape of the hole from an L-shape to a rectangular shape. Due to variations of drivetrains, the hole may need to be enlarged as well as made into a rectangular shape.

Once there is sufficient clearance for the shifter handles, assemble the pivot shaft (715579), both handles (715568M & 715570R), the 5-16" flat washer, the 5/16" lock washer, and the 5/16"-18 nut together as a unit. Push the handles up through the floor and thread the pivot shaft into the side of the transmission.

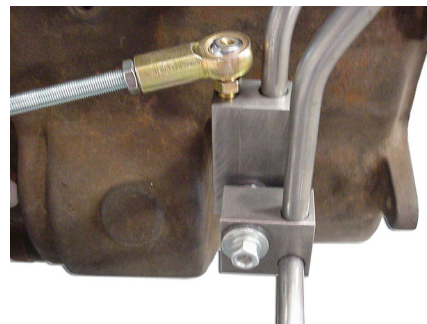

Now install the two 3/8" jam nuts and ball joints onto the 3/8" all thread, and bolt this assembly to the high/low shift handle and arm. Adjust the length so that the handle is pointing straight up when the transfer case is in neutral. (Cutting of the all thread may be necessary for some vehicles to achieve this). Repeat this same process for the mode shifter assembly using the 5/16" all thread, jam nuts, ball joint, and female heim joint. The female heim joint mounts to the mode shaft with the supplied clevis pin and cotter pin.



Once the transfer case shifts in a satisfactory manner, mount the shift boot over the hole in the floor using the metal ring supplied. Use approximately 4 self tapping screws to go through the boot, metal ring, and floor. Finish the installation by adding the 1/2" jam nuts and the shift knobs.

SPECIAL NOTE: The components packaged in this kit have been assembled and machined for specific type of conversions. Modifications to any of the components will void any possible warranty or return privileges. If you do not fully understand modifications or changes that will be required to complete your conversion, we strongly recommend that you contact our sales department for more information. This instruction sheet is only to be used for the assembly of Advance Adapter components. We recommend that a service manual pertaining to your vehicle be obtained for specific torque values, wiring diagrams and other related equipment. These manuals are normally available at automotive dealerships and parts stores.