

## ASSEMBLY INSTRUCTION SHEET

Page Rev. Date: 09/15/14

# 5.5" L-H DROP UNIVERSAL ATLAS SHIFTER

### KIT CONSISTS OF:

No.	Qty	Part No.	Description
1.	1 KIT	302010	ATLAS BAGGED HARDWARE KIT
2.	1 KIT	302011	ATLAS BOOT & KNOB KIT
3.	1	302051	TWIN STICK BASE MOUNT
4.	1	302053	TWIN STICK EXTENSION TUBE 5.5"
5.	2	302058	TWIN STICK HANDLE (STR)
6.	1	302076	1/2"-13 x 9" STUD BOLT
7.	10"	303100	3/8" HEAT SHRINK
8.	3	303121	HEX JAM NUT 1/2"-13 PLATED
9.	2	723759	3/8"-24 x 6" ALL THREAD GRD 5



The shift tower in this photo as shown would index onto the D.O.M. tubing and would fit a left drop case. Right drop cases would require the tower to be flip to the other side to index over the D.O.M. tubing.

**As of January 1, 2005, we have changed the design of our shifter tower. We no longer use a set of Zerk fittings on the tower and have omitted the white nylon bushings. The new design uses a Igus black bushing which does not require grease. These bushings are not interchangeable.**

White bushings: 303080 (large) 4 required  
303095 (small) 4 required  
Black bushings: 303081 (large) 4 required  
303096 (small) 4 required

Atlas Shifter Linkage Upgrade: The connection rods for the Atlas were designed to be universal so they could be adjusted for the various drivetrain lengths. The stock linkage works well for the majority of applications and vehicles. The extreme racers and rock crawlers, on the other hand, were looking for a linkage that would withstand the abuse that they are putting their rigs through. The two kits offered are upgrades that work with the standard handles and use heim joints that are bolted to the Atlas linkage. Anyone can upgrade to these kits as they will work on all Atlas ridged mounted twin stick applications, [P/N 303040](#) or [P/N 303041](#). View the applications descriptions online.

### SHIFTER INSTALLATION (2sp and 4sp main case)

1. Install the shifter base to the face of the Atlas using the three S.H.C.S. 3/8"-16 x 1". These bolts have a sealant patch that will prevent leakage on the threads. This should be done before the Atlas is installed into the vehicle.
2. Install 1/2"-13 all-thread and jam nut to the shifter base.
3. Slide the shifter tower along the all-thread stud until the shifter arms are at the center of your stock floor cutout.
4. Measure between the tower and the base to obtain the correct extension tube length.
5. Remove the tower and install the extension tube.
6. Assemble the shift handles to the shift tower.
7. Install the shift tower assembly to the extension tube using the lock nut on 1/2"-13 all-thread to secure.
8. Install the brass shift rod ends to the Atlas shift rods. Teflon tape should be used on the threaded portion of the shift rod.
9. With the Atlas in neutral and the shift handles parallel with the shift tower, measure the distance for the linkage rods.
10. Connect the shift buttons and heat shrink tubing to the 3/8"-24 all-thread at the distance measured. Make sure that the all-thread is flush with the outside edge of the shift button. Cut all-thread if necessary.
11. Assemble the linkage rods to the shift handle and brass portion of the shift rod and verify the shift handles are parallel to the tower.
12. Install the e-clips to retain the buttons to the mating parts.
13. Make sure the brass shift rod ends are not too tight. They should be finger tight.
14. Modify the floorboard if necessary.
15. Install the rubber boot and boot ring to the floorboard. (Note: On some twin stick configurations, the boot ring may need to be cut in order to fit around the Atlas twin sticks).

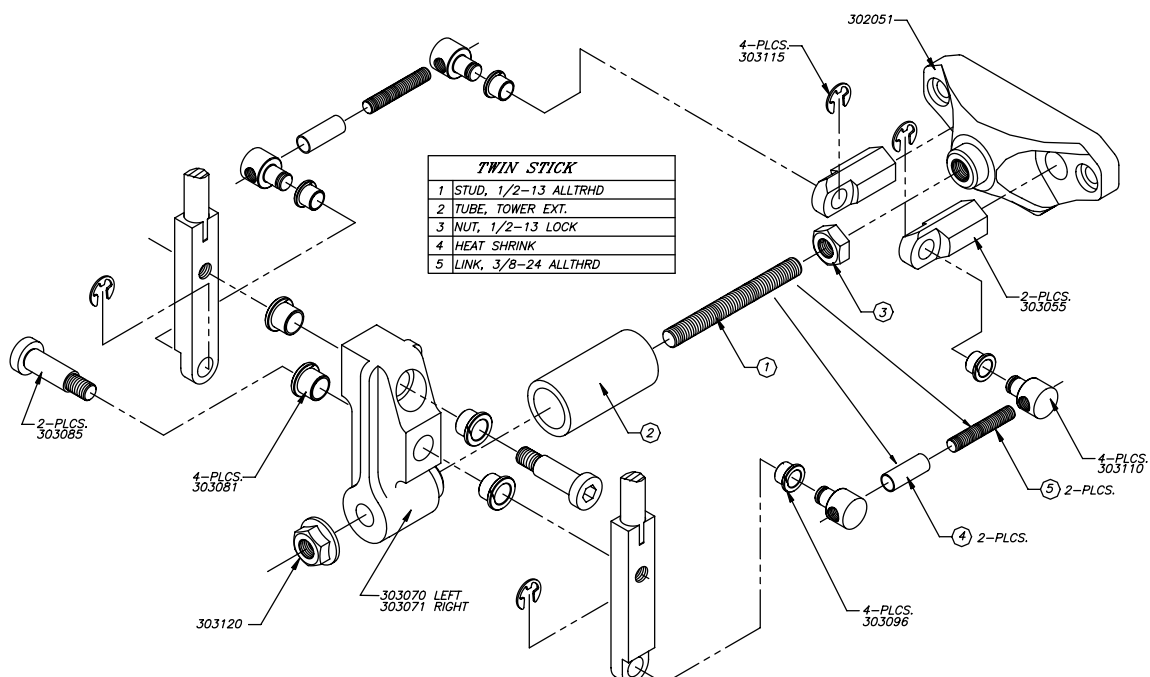

**ADVANCE ADAPTERS, INC.**

**P/N: 303000L**  
**P/N: 303001R**

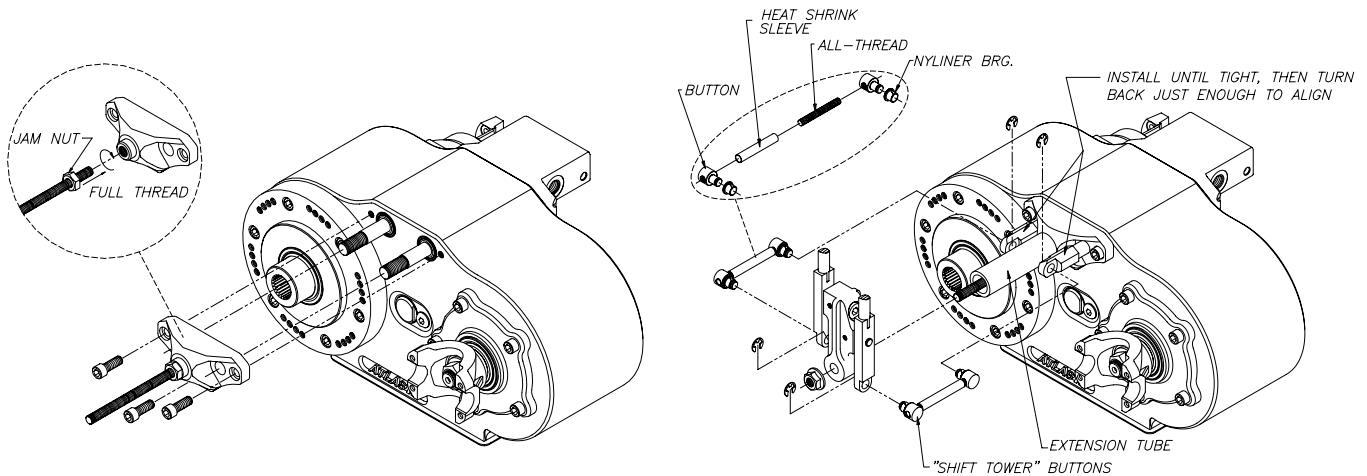

Atlas shifter problem check list: When installing the twin stick shifters, there are a few key areas that must be addressed. One of the most common difficulties we hear is that "my unit isn't shifting fully into one of the gear ratios". Incorrect adjustment of the shift handles to the linkage rods is normally the cause. With both shift rods in neutral, the linkage rod (connected to the shift handles) must be parallel with the aluminum shift tower. Refer to the photo left.



Another concern that we've heard is that "my Atlas seems to be hard to shift". This problem could be one of two areas. The brass shift rod ends that the shifter linkage rods connect to are too tight, causing a binding effect on the shifter linkage. The brass shift rod ends should be installed until tight, then loosened enough to align to the shifter button.

If a unit has a tendency to pop out of gear, an area to check is proper floorboard clearance in relation with the shift handles. This problem mainly occurs on Jeep TJs, since floorboard modifications are required. Most reported problems have been overcome by simply providing additional clearance. The problem of popping out of gear can also be caused by incorrect alignment of the shifter handles as previously discussed and/or a unit in which the detent set screws have been loosened.

The last of the most common dilemmas we hear is that "the shifter linkage came apart while in operation". The area in question is the all-thread linkage rods. These rods fit into the two shift buttons. To prevent the all-thread from unscrewing out of the shift buttons, a portion of the heat shrink tubing should have been installed (o-rings on a TJ automatic). The heat shrink tubing or o-rings act as a jam nut to prevent the all-thread from unscrewing. **DO NOT** use a jam nut on these linkage rods because it will cause binding of the shifter linkage.