



P.O. Box 247, 4320 Aerotech Center Way
 Paso Robles, CA 93447
 Telephone: (800) 350-2223 Fax: (805) 238-4201
 PAGE 1 OF 3 Page Rev. Date: 08-08-19
 P/N: 50-3102

GM TH350 AUTOMATIC TO SCOUT DANA 18/20 OR DANA 300 1945-79

KIT CONSISTS OF:

No.	Qty	Part No.	Description
1.	1	51-1700	CASTING (Ref: 711117)
2.	1	52-1200	SHAFT (Ref: 711312)
3.	1	52-1301	SPUD SHAFT (Ref: 711313-23)
4.	1	716062	NYLON BUSHING FOR T350 OUTPUT SHAFT (CUSTOMER MUST INSTALL)
5.	1	716308	BEARING
6.	1	716450	SNAP RING
7.	1	716456	SNAP RING (T/A N5000-334)
8.	1	716511	"O"-RING
9.	1	716568	GASKET
10.	2	716711	SEAL
11.	4	723728	3/8"-16 X 2-1/4" S.H.C.S.
12.	1	724319	7/16"-20 X 3/8" SET SCREW
13.	1	728701	7/8" NYLOCK NUT
14.	1	JP001	JEEP INSTRUCTION MANUAL

OPTIONAL ITEMS:

Qty	Part No.	Description
1	716003	CROSSMEMBER MT
1	716302	SEALED BEARING
1	716001 or	
	716002	T86/T90 BRG. RET
1	716010	MODULATOR

SPECIAL NOTE: The components packaged in this kit have been assembled and machined for a specific type of conversion. Modifications to any of the components will void any possible warranty or return privileges. If you do not fully understand the modifications or changes that will be required to complete your conversion, we strongly recommend that you contact our sales department for more information. This instruction sheet is only to be used for the assembly of Advance Adapter components. We recommend that a service manual pertaining to your vehicle be obtained for specific torque values, wiring diagrams and other related equipment. These manuals are normally available at automotive dealerships and parts stores. Always inspect parts prior to installation for consistency with the OEM offering (e.g., spline count, tooth count, lubrication points, etc.).



P.O. Box 247, 4320 Aerotech Center Way
Paso Robles, CA 93447
Telephone: (800) 350-2223 Fax: (805) 238-4201
PAGE 2 OF 3 Page Rev. Date: 08-08-19
P/N: 50-3102

GM TH350 AUTOMATIC TO SCOUT DANA 18/20 OR DANA 300 1945-79

GM TH350 3 SPEED

The General Motors TH350 has a case length of 21-1/2", 13 bolts for holding the oil pan in position and is available in two different engine to transmission bolt patterns. The case is available with a Chevy bolt pattern that has the top two holes 8-1/4" apart or in a Buick bolt pattern that has the top two holes 7" apart. The rear side of the transmission case should have a square bolt pattern that uses 4 bolts. There are several various lengths of output shafts that the transmissions have been furnished with and you must make sure the proper shaft has been installed into the transmission for use with our transfer case kit. When overall transmission length is critical, we standardize on the GM 4WD output shafts that were used in vehicles 1973-79. If the transmission you purchased has the correct output shaft, you can return the new output shaft for credit. All TH350 output shafts will have 27 splines. The speedometer gear is normally located in the tailhousing, but when adapting it to the transfer case the location will change to the back side of the transfer case. The rear transmission support is located in the main case just forward of the tailhousing connection. This can be used for supporting the crossmember on some installations, but most of our kits provide support on the new adapter housing.

When installing the new transfer case adapter, make sure that the coupler and the output shaft do not bottom out. We have found on occasion that a transmission output shaft may be slightly longer than we have allowed for and when coupling into our new spud shaft, we find a small amount of interference. The adapter housing and spud shaft must be assembled to the back of the transmission without interference. **DO NOT FORCE THE NEW TAILHOUSING ONTO THE TRANSMISSION.** If assistance is needed, please feel free to call the number listed above.

When assembling the adapter housing to the transmission case, we have provided you with a new square-type "O"-ring seal to prevent fluid leakage. This seal is a stock GM item that is used on all TH350 installations

On most installations, a pan modification will be required for clearance of the front Universal yoke. On early model Jeeps up to 1965, it may be necessary to change the front transfer case yoke to the smaller design (from a 1966-1971 Buick V6 application). For additional front driveline clearance, we recommend that the engine and transfer case be offset to the driver's side approximately 1" of centerline. This offset will help the front drive shaft clear the TH350 oil pan.

If you have selected a transmission that has the old style modulator, then we recommend the use of the Advance Adapters adjustable modulator, **Part No. 716010**. This will also allow for additional driveshaft clearance.

All installations will require the use of a transmission cooler. The cooler can be either installed in the radiator or a remote location is acceptable. The transmission shift control can either be a Hurst floor mounted type shifter or sometimes the existing column shift can be modified on certain applications.

This kit is designed to replace the Scout transmissions that used a 23 spine output gear to the transfer case.

This adapter kit is supplied with a special set screw, **Part No. 724319**. It is to be used on Dana 18 transfer cases that have the dual shift lever type transfer case. The set screw will replace the square headed bolt that is used on the inside portion of the shift handle mounting. By using the set screw configuration, additional clearance can be obtained.

CAUTION: This adapter is not to be used with a GM 700R-4 automatic overdrive transmission. The adapter length is not long enough to allow for front drive shaft clearance when using the Scout Dana 18/20 or Dana 300 transfer cases.

SPECIAL NOTE: The components packaged in this kit have been assembled and machined for a specific type of conversion. Modifications to any of the components will void any possible warranty or return privileges. If you do not fully understand the modifications or changes that will be required to complete your conversion, we strongly recommend that you contact our sales department for more information. This instruction sheet is only to be used for the assembly of Advance Adapter components. We recommend that a service manual pertaining to your vehicle be obtained for specific torque values, wiring diagrams and other related equipment. These manuals are normally available at automotive dealerships and parts stores. Always inspect parts prior to installation for consistency with the OEM offering (e.g., spline count, tooth count, lubrication points, etc.).

**GM TH350 AUTOMATIC TO
SCOUT DANA 18/20 OR DANA 300 1945-79**

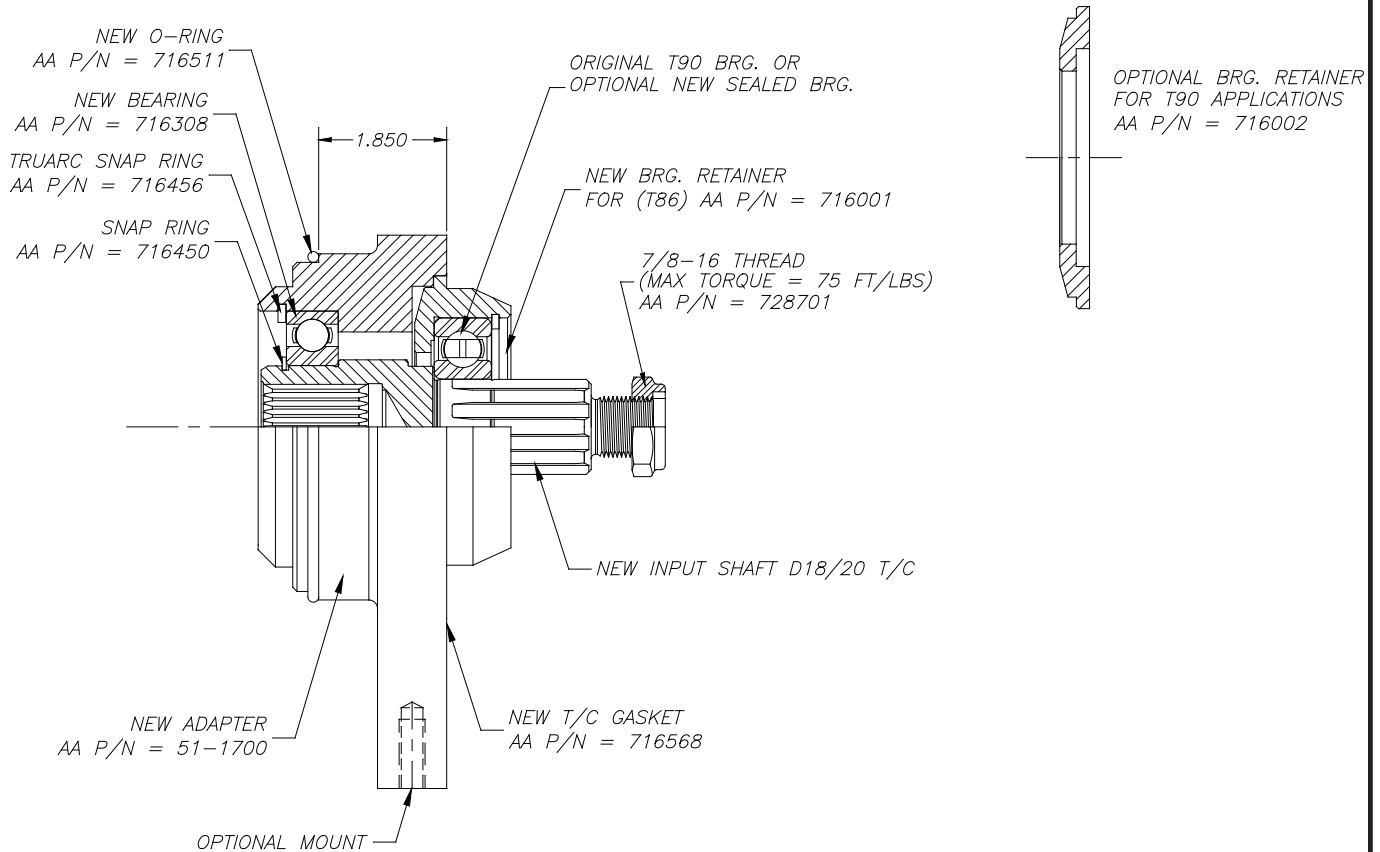

SPECIAL NOTE: The components packaged in this kit have been assembled and machined for a specific type of conversion. Modifications to any of the components will void any possible warranty or return privileges. If you do not fully understand the modifications or changes that will be required to complete your conversion, we strongly recommend that you contact our sales department for more information. This instruction sheet is only to be used for the assembly of Advance Adapter components. We recommend that a service manual pertaining to your vehicle be obtained for specific torque values, wiring diagrams and other related equipment. These manuals are normally available at automotive dealerships and parts stores. Always inspect parts prior to installation for consistency with the OEM offering (e.g., spline count, tooth count, lubrication points, etc.).