

ADVANCE ADAPTERS INC.

P.O. Box 247, 4320 Aerotech Center Way
Paso Robles, CA 93447

Telephone: (800) 350-2223 Fax: (805) 238-4201

P/N: 50-8601

Old Part No: 711086-21

PAGE 1 OF 2

Page Rev. Date: 08-05-15

DANA 18/20 TRANSFER C. TO ALL JEEP TRANSMISSIONS 1987-89 (21-SPL OUTPUT)

KIT CONSISTS OF:

No.	Qty	Part No.	Description
1.	1	51-7700	ADAPTER CASTING (Ref: 711177)
2.	1	52-8601	SPUD SHAFT (21-Splines) (Ref: 711386-21)
3.	1	716568	GASKET
4.	1	716700	SEAL
5.	10	723704	LOCK WASHER 3/8 ZINC
6.	10	723722	3/8"-16 x 1-1/4" H.H.C.S
7.	1	723731	S.H.C.S. 3/8-16 X 1 ZINC
8.	1	728701	7/8"-16 NUT
9.	1	JP001	JEEP INSTRUCTION MANUAL

OPTIONAL ITEMS:

Qty	Part No.	Description
1	716001 or 716002	T86/T90 BRG RET

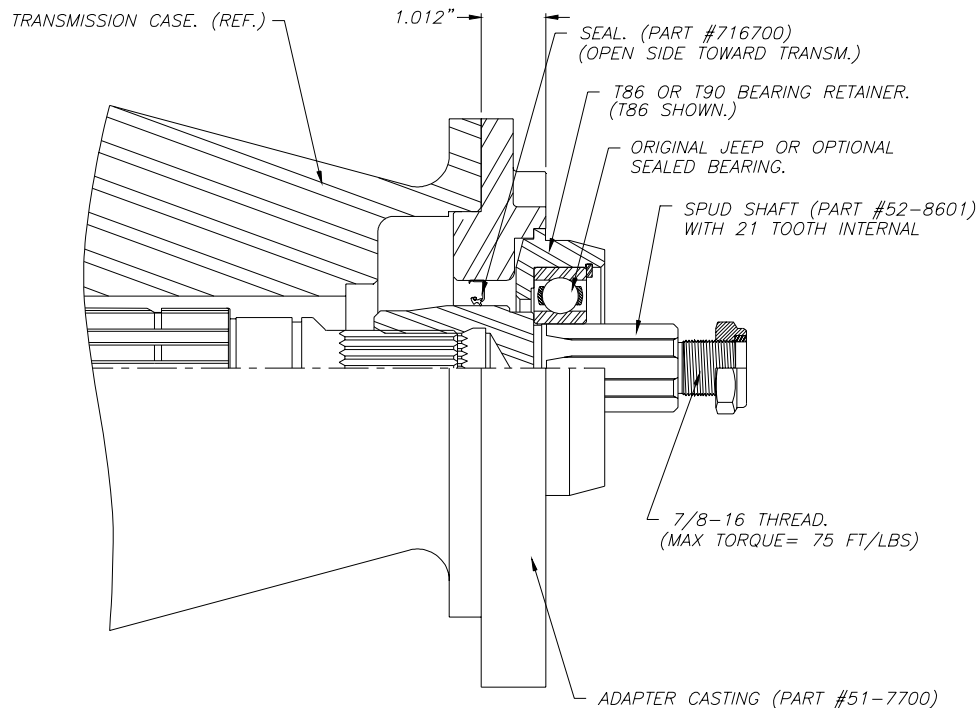

SPECIAL NOTE: The components packaged in this kit have been assembled and machined for specific type of conversions. Modifications to any of the components will void any possible warranty or return privileges. If you do not fully understand modifications or changes that will be required to complete your conversion, we strongly recommend that you contact our sales department for more information. This instruction sheet is only to be used for the assembly of Advance Adapter components. We recommend that a service manual pertaining to your vehicle be obtained for specific torque values, wiring diagrams and other related equipment. These manuals are normally available at automotive dealerships and parts stores.

ADVANCE ADAPTERS INC.

P.O. Box 247, 4320 Aerotech Center Way
Paso Robles, CA 93447

Telephone: (800) 350-2223 Fax: (805) 238-4201

P/N: 50-8601

Old Part No: 711086-21

PAGE 2 OF 2

Page Rev. Date: 10-15-03

DANA 18/20 TRANSFER C. TO ALL JEEP TRANSMISSIONS 1987-89 (21-SPL OUTPUT)

AX5 & PEUGEOT BA/10

This kit is designed for any Jeep transmission 1987 & newer having a 21 spline output shaft to adapt to the model 18 or 20 transfer case.

On installations using a 2 piece main shaft, make sure that the coupler and the output shaft do not bottom out. We have found on occasion that a transmission output shaft may be slightly longer than we have allowed for; and when coupling into our new spud shaft, we find a small amount of interference. The adapter housing and spud shaft must be assembled to the back of the transmission without interference. **DO NOT FORCE THE NEW TAILHOUSING ONTO THE TRANSMISSION.** If assistance is needed, please free to call the number listed above.

1. Using the original Jeep bearing or a new 307 bearing, you must first install the spud shaft onto the new bearing.
2. Install the appropriate bearing retainer into the back of the adapter housing, Part No. 711177. The retainer will either be a T90 or T86. If a T86 retainer is used, then be sure to install the external snap ring.
3. Install spud shaft with bearing onto the bearing retainer.
4. Install the oil seal with the open side towards the transmission.
5. Most stock Jeep tailhousing have a oil weep hole that leaks when the seal goes bad. Our spud shaft does not contact this stock seal on all applications. We recommend plugging the weep hole / slot with silicone to prevent any oil leaking from the transfer case.
6. Place the gasket over the transfer case face.
7. On large hole transfer cases, your can now install your output gear onto the new spud shaft and secure it with new nylon lock nut. Maximum torque must be 75 ft./lbs.
8. On small hole transfer cases, you will need to install the gear through the inspection cover of the transfer case. On installations that were previously equipped with a gear spacer, you will eliminate the spacer.
9. Bolt the adapter assembly to the transfer case using the original bolts from the transfer case side and the special socket head cap screw from the adapter side.
10. With the adapter completely assembled to the transfer case, you can now install the adapter assembly to the main transmission adapter. We recommend using RTV blue silicone between these two surfaces.

SPECIAL NOTE: The components packaged in this kit have been assembled and machined for specific type of conversions. Modifications to any of the components will void any possible warranty or return privileges. If you do not fully understand modifications or changes that will be required to complete your conversion, we strongly recommend that you contact our sales department for more information. This instruction sheet is only to be used for the assembly of Advance Adapter components. We recommend that a service manual pertaining to your vehicle be obtained for specific torque values, wiring diagrams and other related equipment. These manuals are normally available at automotive dealerships and parts stores.